

LMV CONNECTORS

Military style connectors manufactured in accordance with IEQC-CECC specification BS/CECC 75201-004, which includes the safety requirements for safe use in mains applications.





LMV Range is produced in the UK in accordance with IEQC-CECC specification BS/CECC 75201-004, which includes the safety requirements for safe use in mains applications, providing the connectors are used with the recommended Earth Link and outlet accessory sets. The maximum current capability ranges from 7.5 to 32A and they are suitable for direct, 3 way mains connections in 250V AC or DC applications.

The Weald LMV range has a brass shell. The connector can be supplied in various finishes including RoHS compliant variants. The LMV range is available in two shell sizes in a variety of free and fixed shell styles including cable mount, fixed square and oval flange panel mount and cable mounted coupler. The three solder bucket contacts - earth, live and neutral - are gold plated.

The shells are earthed, feature finger proof live and neutral contacts and have the safety of a leading earth contact. We can also supply EMC 360° screen termination versions. Also available are strain relief backshells with a cable clamp as well as protective caps and a full range of tooling.

Contents

Introduction	2, 4
General information	
Safety information	5
Intermateability with LMF and LMG Connector Ranges	5
Features and benefits	6
Characteristics	7
Connection system	7
Ordering information	
Connector and accessory part numbering system	8
Standard connector part numbers	9
Cable outlet accessory sets	10
Various accessories	11
Protective caps	12, 13
Assembly tooling	14
Connector dimensions	
Free connectors	15
Fixed square flange connectors	16
Fixed round flange connectors	17
Mounting details	18
Wiring instructions	
Using screened multicore cable	19, 20
Using unscreened multicore cable	21
Earth link fitting details	22
Product safety information	23

Lodge Group

Established in 1976, Weald Electronics is part of the privately-owned Lodge Group which includes the connector distributor FC Lane Electronics and its Autosport Division, Lane Motorsport.



Lodge Group Headquarters

Weald Electronics is predominantly known for its comprehensive selection of circular bayonet and screw coupling power and filtered circular connectors, PCB Edge Card, two-part PCB and sub-miniature plastic-bodied circular connectors.

To complete your interconnection solution, Weald manufactures protective caps and backshells for MIL-DTL-38999 and 26482 applications as well as protective caps, nut plates and gaskets for use right across motorsport.

With design, manufacturing and test facilities at its Slinfold Lodge HQ, Weald Electronics is able to tailor a connector solution to exactly meet a customer's specific requirement on surprisingly short lead times. Standard products are normally available by next day.

Products from Weald Electronics Ltd are available from FC Lane Electronics Ltd.

t: +44 (0) 1403 790 661

e: sales@fclane.com

w: fclane.com

LMV Range General Safety Information

The performance of the connectors listed in this catalogue at all times exceeds the maximum continuous bunched rating of the appropriate size wire or cable of equivalent temperature rating, and this bunched rating shall be the determining factor. To achieve the BS CECC 75201-004 specification's standards of safety, the selected connector must be correctly assembled with the recommended outlet accessory set and earth link. For more details see pages 7, 10, 14 and 16. It is recommended that a connector with socket/female contacts is wired to the power source and that the supply is always isolated before connection or disconnection. See drawing below. The establishment of electrical safety factors is the responsibility of the user.

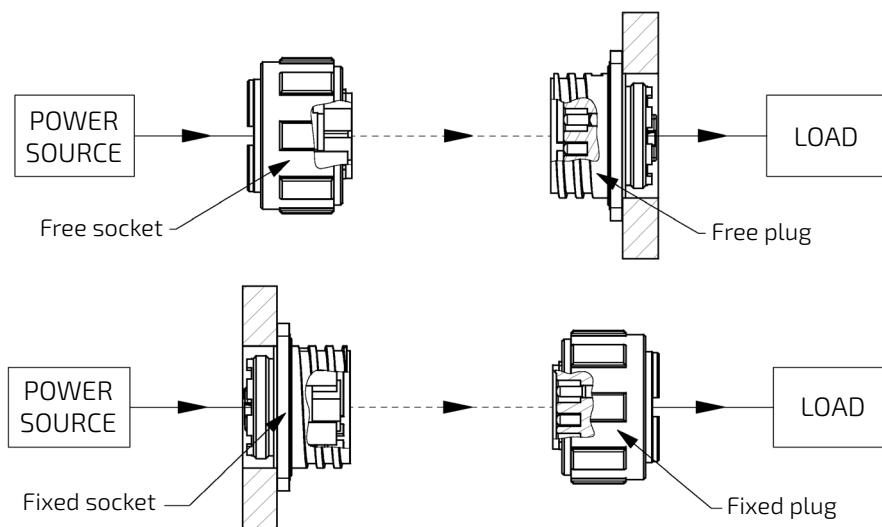

For additional safety information see page 23.

Intermateability with LMF and LMG Connector Ranges

LMV connectors will not intermate with Weald Electronics Ltd's LMF or LMG connector ranges. However, LMV connectors can be readily interchanged with shell size 1 or 2 LMF or LMG connector systems already installed in equipment that does not comply with the BS EN 60950 safety standards. Panel piercing and space envelopes are identical to sizes 1 and 2 LMF and LMG connectors.

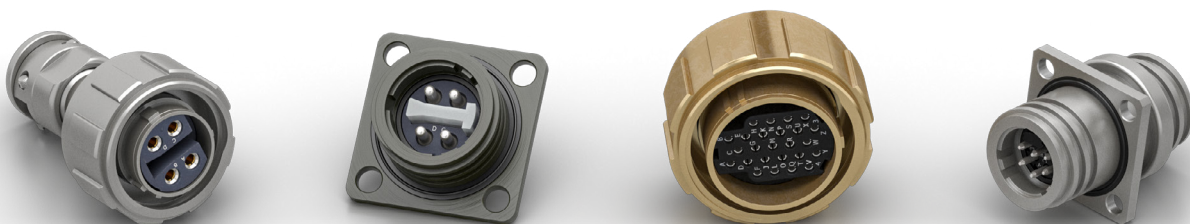

Features and Benefits

Connectors

- Special purpose connectors developed from the popular BS 9522 F0014 (LMG) range
- Operating temperature range of -55°C to +100°C
- Insert mouldings designed to give maximum surface tracking and clearance distances
- Insert orientation normal 0 supplied as standard
- Finger probe proof live and neutral contacts provided with the safety of a leading earth contact
- All contacts have solder terminations
- Grounded shell to earth contact
- 7.5 A (shell size 1) and 20 A or 32 A (shell size 2) current ratings available
- Connector styles: free plug or socket, fixed square or round flange plug or socket, cable coupler plug or socket
- Shells are manufactured from brass and have a coarse, quick action coupling thread
- Shells have a high resistance to corrosion and are supplied as standard with an olive drab chromate conversion over cadmium plate finish
- Fixed connectors are environment resistant with barrier and panel seals
- Free connectors (including couplers) are environmentally resistant and barrier sealed
- Contacts are finished with gold plate as standard

Accessories

- Accessories are available to suit multi-core screened and unscreened cables
- Backend accessory sets are available with straight or angled outlets terminating in either a union nut or cable clamp.
- Special retaining glands to prevent ingress of moisture are an integral part of the accessory sets
- Connector shell and cable outlet, to earth contact 'link' accessory available
- All metallic cable and protective cap accessory parts are manufactured from brass

Other special shell materials are available. Contact local Sales Office for further information.

Note: Brass accessories will only assemble with brass connectors as the product design changes with the material.

Characteristics

Environmental category	55/100/56			
Low pressure severity	300 millibars			
Temperature range	-55°C to +100°C In practice the temperature will be de-rated to that of the cable			
Maximum current per contact through both live and neutral contacts simultaneously at 70°C ambient temperature	Size 1 connector 7.5 A Size 2 connector 20 or 32 A			
Working voltage DC or AC peak (sea level) Establishment of the electrical safety factors is the responsibly of the user	Size 1 connector 354 V Size 2 connector 354 V			
Voltage proof DC or AC peak	Size 1 connector 2000 V Size 2 connector 2000 V			
Number of contacts	3 (earth, live and neutral)			
Contact termination	Solder buckets			
Solder bucket bore diameter (max wire diameter)		Size 1	Size 2 - 20A	Size 2 - 32A
	Earth	1.75 mm	2.75 mm	3.10 mm
	Live	1.40 mm	2.75 mm	3.10 mm
	Neutral	1.40 mm	2.75 mm	3.10 mm
Contact finish	Gold Plated			
Polarisation	By shell keys and keyways			
Insert orientation	Standard insert position 0 (special positions available)			
Insert material	Polychloroprene and plastic			
Housing (shell) material	Brass			
Housing (shell) finish as standard (special finishes available)	Olive drab chromate conversion over cadmium plate			
Sealing	Environmentally resistant with barrier or barrier and panel seal. Insert rated at lcm ³ /hr max leakage at pressure differential of 1 bar			

Schematic showing LMV Connector System

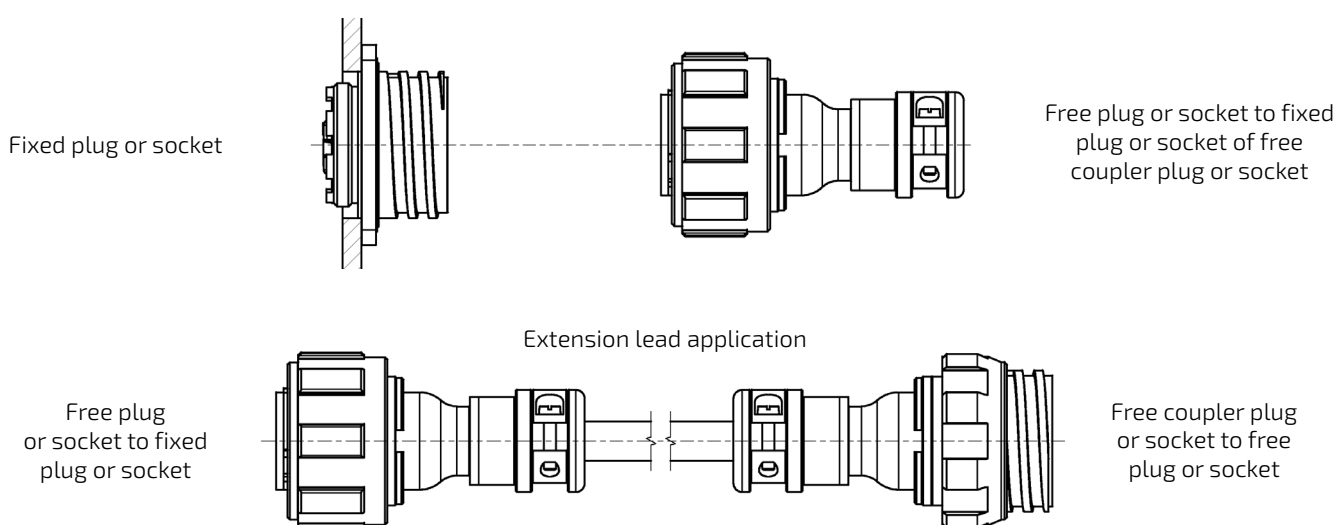

It is recommended that a connector with socket/female contacts is wired to the power source and that the supply is always isolated before connection or disconnection.

Part Numbering System for Connectors and Accessories

Connector part no example: **LMV 2154 (2) 1 M 3 M 0 (100)**

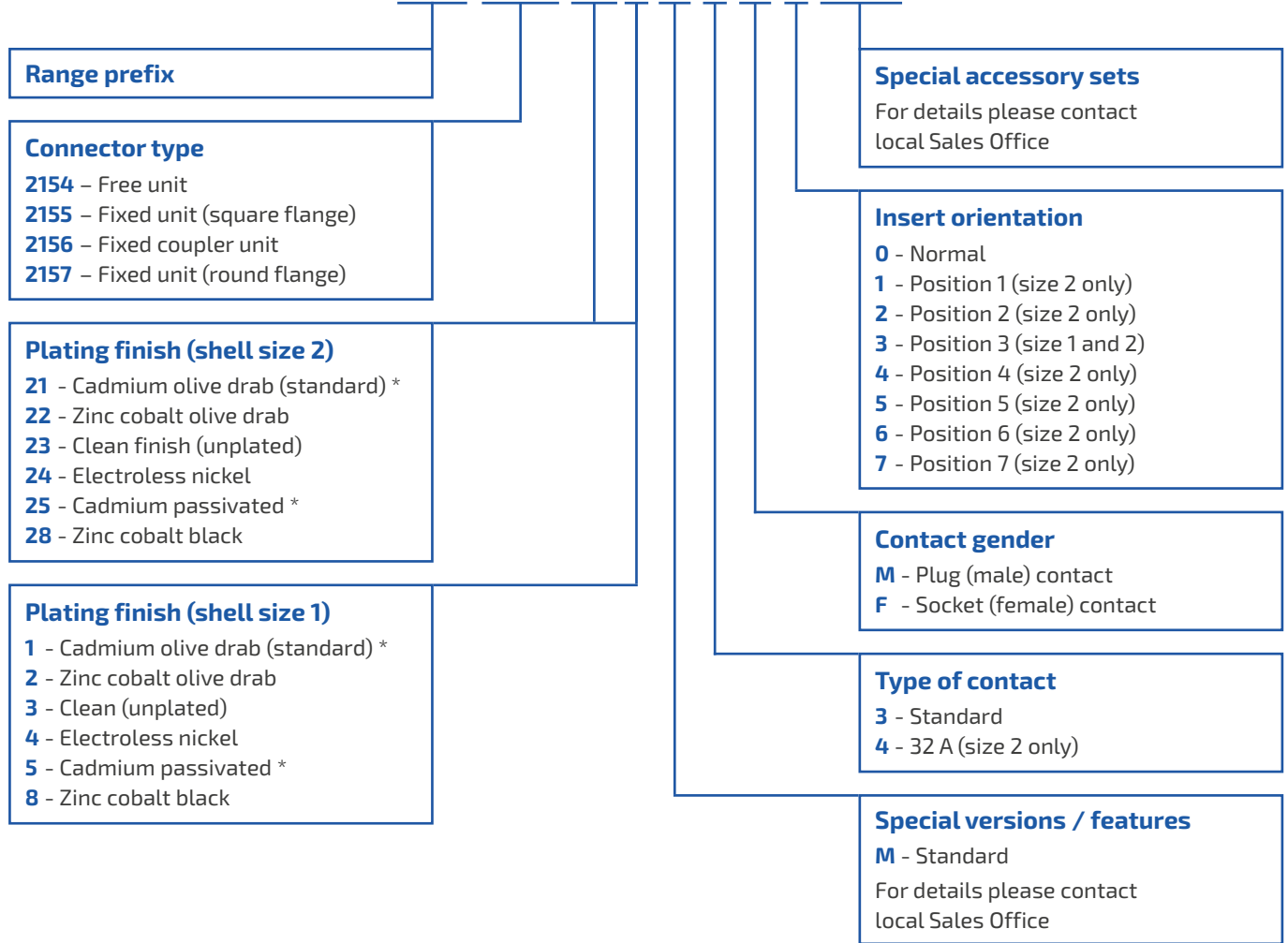

Accessory part no example: **LMA / 1 / 10601 / 2 03**

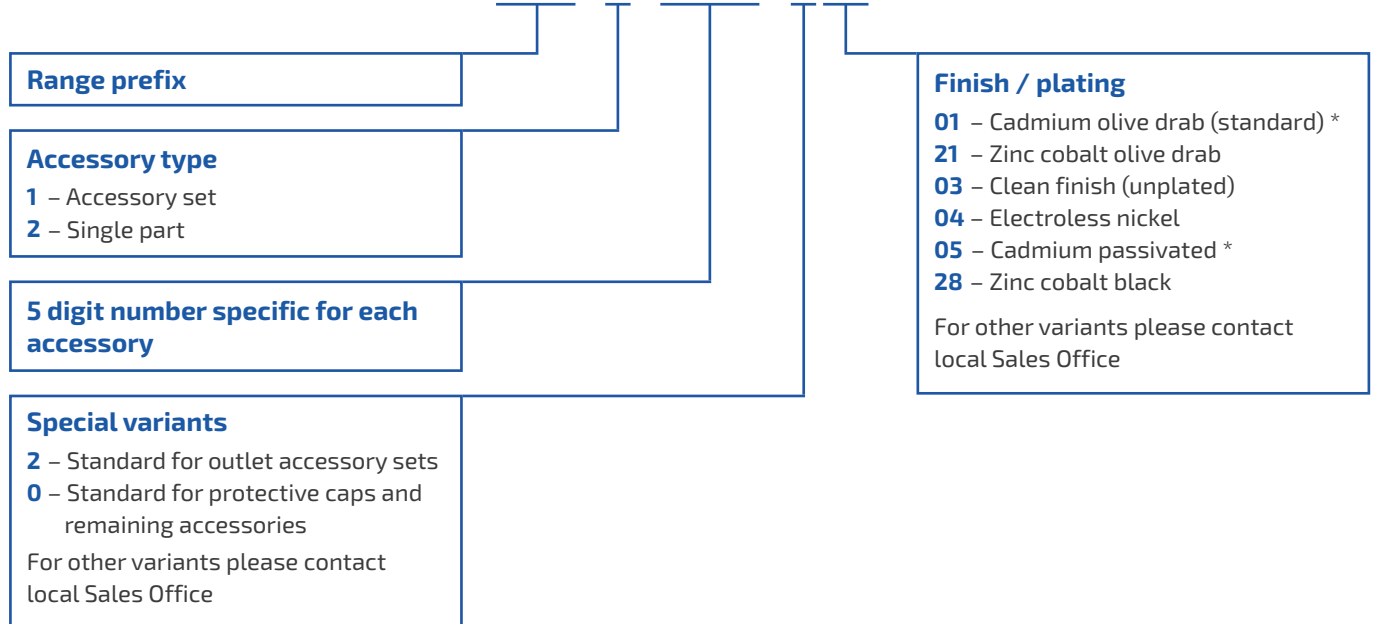

* - Cadmium plated variants are non RoHS compliant.

Standard Connectors

Cadmium olive drab plated

Connector type	Contact type	Shell size 1 - 7.5 A, 354 V Weald Part No. / CECC Part No.*	Shell size 2 - 20 A, 354 V Weald Part No. / CECC Part No.*	Shell size 2 - 32 A**, 354 V
	Plug	LMV 2154-1M3-M0 CECC75201-004 C0103M50 1A1H	LMV 2154-21M3-M0 CECC75201-004 C0203M50 1A1H	LMV 2154-21M4-M0 N/A
	Socket	LMV 2154-1M3-F0 CECC75201-004 C0103F50 1A1H	LMV 2154-21M3-F0 CECC75201-004 C0203F50 1A1H	LMV 2154-21M4-F0 N/A
Free unit	A free unit is typically used with Outlet Accessory Set to connect the cable to fixed units and free coupler units. For Outlet Accessory Set ordering details refer to page 10. Outlet Nuts are supplied with these connectors.			
	Plug	LMV 2155-1M3-M0 CECC75201-004 A0103M50 1A 1H	LMV 2155-21M3-M0 CECC75201-004 A0203M50 1A 1H	LMV 2155-21M4-M0 N/A
	Socket	LMV 2155-1M3-F0 CECC75201-004 A0103F50 1A 1H	LMV 2155-21M3-F0 CECC75201-004 A0203F50 1A 1H	LMV 2155-21M4-F0 N/A
Fixed unit (Square flange)	A fixed unit - four hole corner mounting - with the facility to accept Outlet Accessory Sets. For Outlet Accessory Set ordering details refer to page 10. When these are required an Outlet Nut must be specified as an additional item. For Outlet Nut ordering details refer to page 11.			
	Plug	LMV 2156-1M3-M0 CECC75201-004 D0103M50 1A 1H	LMV 2156-21M3-M0 CECC75201-004 D0203M50 1A 1H	LMV 2156-21M4-M0 N/A
	Socket	LMV 2156-1M3-F0 CECC75201-004 D0103F50 1A 1H	LMV 2156-21M3-F0 CECC75201-004 D0203F50 1A 1H	LMV 2156-21M4-F0 N/A
Free coupler unit	A free coupler unit is typically used with Outlet Accessory Set as a means of connecting two free cables and mates with the free units only. For Outlet Accessory Set ordering details refer to page 10. Outlet Nuts are supplied with these connectors.			
	Plug	LMV 2157-1M3-M0 CECC75201-004 B0103M50 1A 1H	LMV 2157-21M3-M0 CECC75201-004 B0203M50 1A 1H	LMV 2157-21M4-M0 N/A
	Socket	LMV 2157-1M3-F0 CECC75201-004 B0103F50 1A 1H	LMV 2157-21M3-F0 CECC75201-004 B0203F50 1A 1H	LMV 2157-21M4-F0 N/A
Fixed unit (Round flange)	A fixed unit - single hole mounting - with the facility to accept Outlet Accessory Sets. For Outlet Accessory Set ordering details refer to page 10. When these are required an Outlet Nut must be specified as an additional item. For Outlet Nut ordering details refer to page 11.			

* - CECC Part Numbers shown for reference only; ** - For maximum cable size refer to page 7.

Outlet Accessory Sets for Unscreened Cable

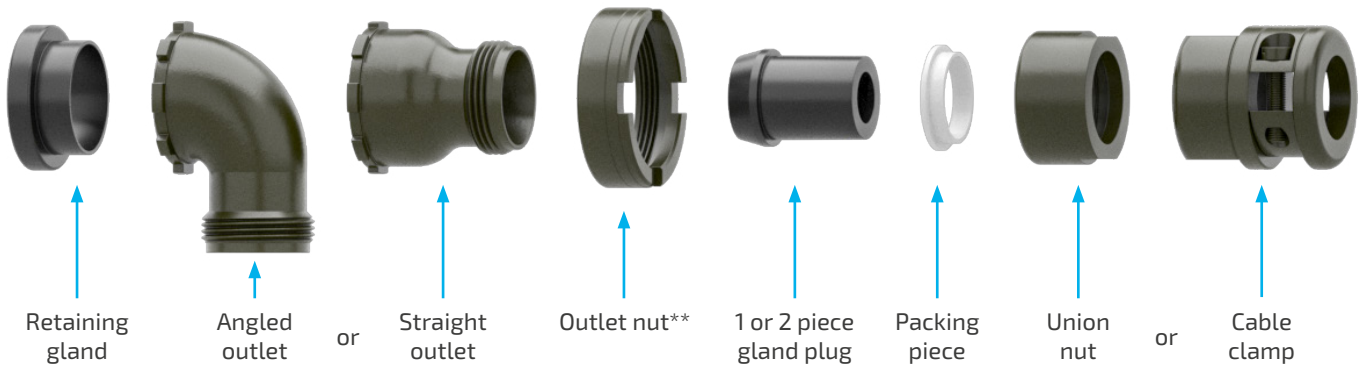

Outlet accessory set type			Shell size 1 Cable O/D 6.4, 8.0 max	Shell size 2 Cable O/D 7.5 min, 10.2 max
Outlet accessory set with union nut	Straight Outlet	Weald Part No.	LMA/1/41507/201	LMA/1/41534/201
		CECC Part No.*	CECC 75201-004 A01 A A	CECC 75201-004 A02 A A
	Right Angled Outlet	Weald Part No.	LMA/1/41509/201	LMA/1/41535/201
		CECC Part No.*	CECC 75201-004 A01 B A	CECC 75201-004 A02 B A
Outlet accessory set with cable clamp	Straight Outlet	Weald Part No.	LMA/1/41508/201	LMA/1/41536/201
		CECC Part No.*	CECC 75201-004 A01 C A	CECC 75201-004 A02 C A
	Right Angled Outlet	Weald Part No.	LMA/1/41510/201	LMA/1/41537/201
		CECC Part No.*	CECC 75201-004 A01 D A	CECC 75201-004 A02 D A

Outlet Accessory Sets for Screened Cable

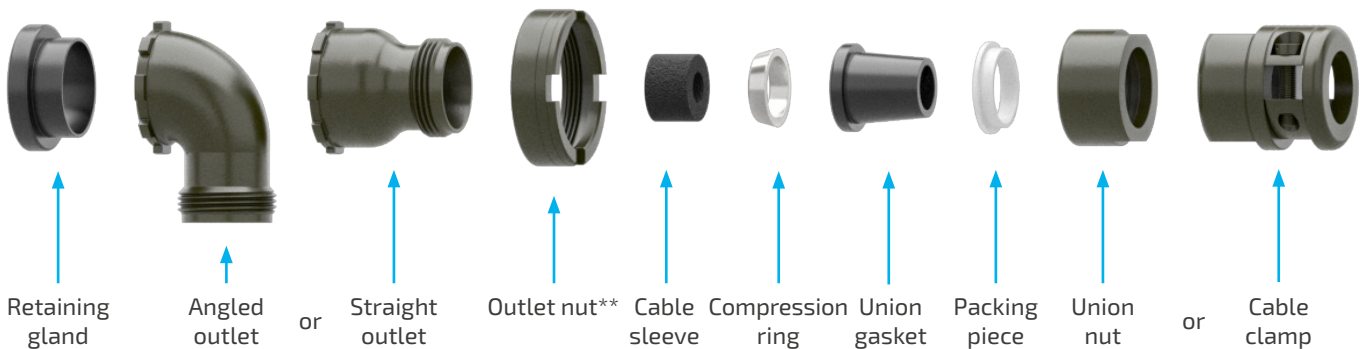



Outlet accessory set type			Shell size 1 Cable O/D 6.15 min, 7.65 max	Shell size 2 Cable O/D 7.5 min, 10.2 max
Outlet accessory set with union nut	Straight Outlet	Weald Part No.	LMA/1/41513/201	LMA/1/41538/201
		CECC Part No.*	CECC 75201-004 A01 E A	CECC 75201-004 A02 E A
	Right Angled Outlet	Weald Part No.	LMA/1/41515/201	LMA/1/41539/201
		CECC Part No.*	CECC 75201-004 A01 F A	CECC 75201-004 A02 F A
Outlet accessory set with cable clamp	Straight Outlet	Weald Part No.	LMA/1/41514/201	LMA/1/41540/201
		CECC Part No.*	CECC 75201-004 A01 G A	CECC 75201-004 A02 G A
	Right Angled Outlet	Weald Part No.	LMA/1/41516/201	LMA/1/41541/201
		CECC Part No.*	CECC 75201-004 A01 H A	CECC 75201-004 A02 H A

* - CECC Part Numbers shown for reference only; ** - Not included in accessory set - must be ordered separately for fixed connectors. Note: All dimensions are in millimeters (mm)

Various Accessories

Earth links		Shell size 1	Shell size 2
	Weald Part No.	LMA/1/80020/015	LMA/1/80269/015
	CECC Part No.*	CECC 75201-004 A 01 L	CECC 75201-004 A 02 L
<p>Used in conjunction with outlet accessory sets to provide earth continuity to fixed and free bodies. To be fitted in accordance with instructions on page 22 and on packing label. Must be fitted to conform to the safety standards of CECC 75201-004.</p>			

Outlet nuts	Shell size 1		Shell size 2		
	Square flange	Round flange	Square flange	Round flange	
	Weald Part No.	LMA/2/07569/001	LMA/2/07157/001	LMA/2/07570/001	LMA/2/07158/001
	CECC Part No.*	CECC 75201-004 A 01 J A	CECC 75201-004 A 01 K A	CECC 75201-004 A 02 J A	CECC 75201-004 A 02 K A
<p>For fixed square flange and round flange connectors.</p>					

Fixing kits for square flange connectors		Shell size 1	Shell size 2
	Weald Part No.	LMA/1/07615/001	LMA/1/07616/001
	<p>These kits contain the necessary nuts, bolts, washers and bushes that are required for panel mounting square flange style LMV connectors.</p>		

* - CECC Part Numbers shown for reference only

Protective Caps for Free Plugs or Sockets

Available in machined brass or moulded MDPE
(Medium Density Polyethylene)



Protective cap type	Shell size 1 Weald Part No. / CECC Part No.*	Shell size 2 Weald Part No. / CECC Part No.*
Ball chain assembly MDPE moulded cap	LMA/1/41150/001	LMA/1/41153/001
	CECC 75201-004 B01 A A	CECC 75201-004 B02 A A
Nylon cord assembly MDPE moulded cap	LMA/1/41092/001	LMA/1/41095/001
	CECC 75201-004 B01 B A	CECC 75201-004 B02 B A
Screw on MDPE moulded cap only	LMA/2/41172	LMA/2/41173
	CECC 75201-004 B01 C	CECC 75201-004 B02 C
Link chain assembly machined brass cap	LMA/1/04111/001	LMA/1/04112/001
	CECC 75201-004 B01 D A	CECC 75201-004 B02 D A
Nylon cord assembly machined brass cap	LMA/1/04139/001	LMA/1/04140/001
	CECC 75201-004 B01 E A	CECC 75201-004 B02 E A

Protective Caps for Free Coupler Plugs or Sockets

Available in machined brass or moulded MDPE
(Medium Density Polyethylene)



Protective cap type	Shell size 1 Weald Part No. / CECC Part No.*	Shell size 2 Weald Part No. / CECC Part No.*
Ball chain assembly MDPE moulded cap	LMA/1/04119/001	LMA/1/04120/001
	CECC 75201-004 B01 F A	CECC 75201-004 B02 F A
Nylon cord assembly MDPE moulded cap	LMA/1/04129/001	LMA/1/04130/001
	CECC 75201-004 B01 G A	CECC 75201-004 B02 G A
Screw on MDPE moulded cap only	LMA/2/41181	LMA/2/41182
	CECC 75201-004 B01 H	CECC 75201-004 B02 H
Link chain assembly machined brass cap	LMA/1/04124/001	LMA/1/04125/001
	CECC 75201-004 B01 J A	CECC 75201-004 B02 J A
Nylon cord assembly machined brass cap	LMA/1/04134/001	LMA/1/04135/001
	CECC 75201-004 B01 K A	CECC 75201-004 B02 K A

* - CECC Part Numbers shown for reference only

Protective Caps for Fixed Square Plugs or Sockets

Available in machined brass or moulded MDPE

(Medium Density Polyethylene)



Protective caps type	Shell size 1 Weald Part No. / CECC Part No.*	Shell size 2 Weald Part No. / CECC Part No.*
Ball chain assembly MDPE moulded cap	LMA/1/41160/001	LMA/1/41161/001
	CECC 75201-004 B01 L A	CECC 75201-004 B02 L A
Nylon cord assembly MDPE moulded cap	LMA/1/41132/001	LMA/1/41133/001
	CECC 75201-004 B01 M A	CECC 75201-004 B02 M A
Screw on MDPE moulded cap only	LMA/2/41181	LMA/2/41182
	CECC 75201-004 B01 H	CECC 75201-004 B02 H
Link chain assembly machined brass cap	LMA/1/04116/001	LMA/1/04117/001
	CECC 75201-004 B01 P A	CECC 75201-004 B02 P A
Nylon cord assembly machined brass cap	LMA/1/04226/001	LMA/1/04227/001
	CECC 75201-004 B01 R A	CECC 75201-004 B02 R A

Protective Caps for Fixed Round Flange Plugs or Sockets

Available in machined brass or moulded MDPE

(Medium Density Polyethylene)





Protective caps type	Shell size 1 Weald Part No. / CECC Part No.*	Shell size 2 Weald Part No. / CECC Part No.*
Ball chain assembly MDPE moulded cap	LMA/1/41198/001	LMA/1/41199/001
	CECC 75201-004 B01 S A	CECC 75201-004 B02 S A
Nylon cord assembly MDPE moulded cap	LMA/1/41201/001	LMA/1/41202/001
	CECC 75201-004 B01 T A	CECC 75201-004 B02 T A
Screw on MDPE moulded cap only	LMA/2/41181	LMA/2/41182
	CECC 75201-004 B01 H	CECC 75201-004 B02 H
Link chain assembly machined brass cap	LMA/1/41208/001	LMA/1/41209/001
	CECC 75201-004 B01 V A	CECC 75201-004 B02 V A
Nylon cord assembly machined brass cap	LMA/1/41211/001	LMA/1/41212/001
	CECC 75201-004 B01 W A	CECC 75201-004 B02 W A

* - CECC Part Numbers shown for reference only

Assembly Tooling

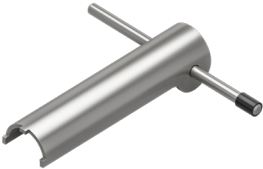
Required for locking cable entry fittings and for mounting fixed units to panels

Special spanner and tommy bar		Shell size 1	Shell size 2
	Special spanner Weald Part No.	LMT/2/00574	LMT/2/00575
	Special spanner CECC Part No.*	CECC 75201-004 C 01 A E	CECC 75201-004 C 02 A E
	Used on fixed units to facilitate tightening of panel locking rings		
	Tommy bar Weald Part No.	LMT/2/00573	LMT/2/00573
	Tommy bar CECC Part No.*	CECC 75201-004 C 00 D E	CECC 75201-004 C 00 D E
	Used with special spanner (as shown)		

Double ended spanner		Shell size 1	Shell size 2
	Weald Part No.	LMT/2/00564	LMT/2/00565
	CECC Part No.*	CECC 75201-004 C 01 C E	CECC 75201-004 C 02 C E
	Used in conjunction with body holder to facilitate tightening of outlet nuts and panel locking rings		

Body holder		Shell size 1	Shell size 2
	Weald Part No.	LMT/1/00261	LMT/1/00262
	CECC Part No.*	CECC 75201-004 C 01 B E	CECC 75201-004 C 02 B E
	Used in conjunction with double ended spanner - locates on front face of connectors		

* - CECC Part Numbers shown for reference only

Connector Dimensions

Free Plug and Free Socket styles

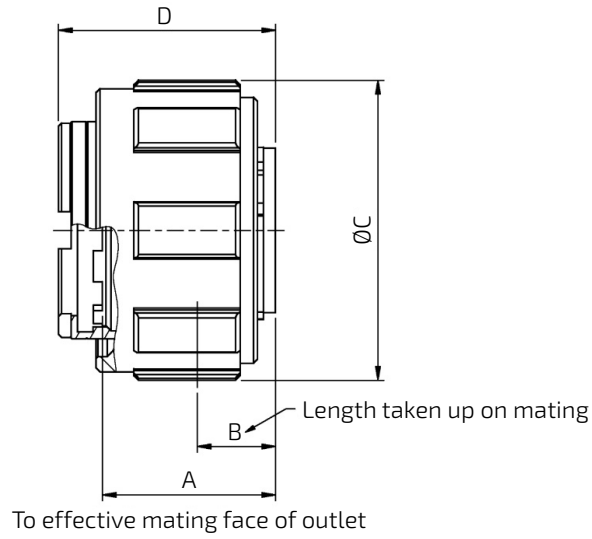

Shell size	A max	B max	ØC max	D max	Coupling thread dia. x 6 TPI modified Acme
1	22.61	8.00	32.51	26.67	Nominal major 25.40
2	22.61	8.00	38.61	26.67	Nominal major 30.96

Free Coupler Plug and Free Socket styles

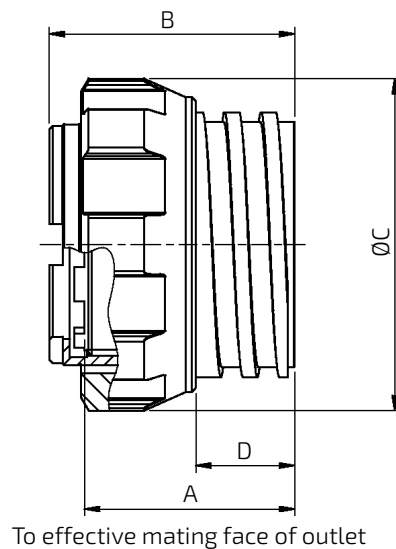

Shell size	A max	B max	ØC max	D max	Coupling thread dia. x 6 TPI modified Acme
1	26.92	30.48	32.51	12.00	Nominal major 25.40
2	26.92	30.48	38.61	12.00	Nominal major 30.96

Note: All dimensions are in millimeters (mm)

Connector Dimensions

Fixed Square Flange Plug and Socket Shell Styles

Supplied complete with panel mounting gasket, corner bushes, nuts, bolts and washers. Bolts should be mounted with bolt heads on the mating side of the connectors. Lengths of bolts are dependent upon panel thickness. With those supplied max. panel thickness is 3.18 mm.

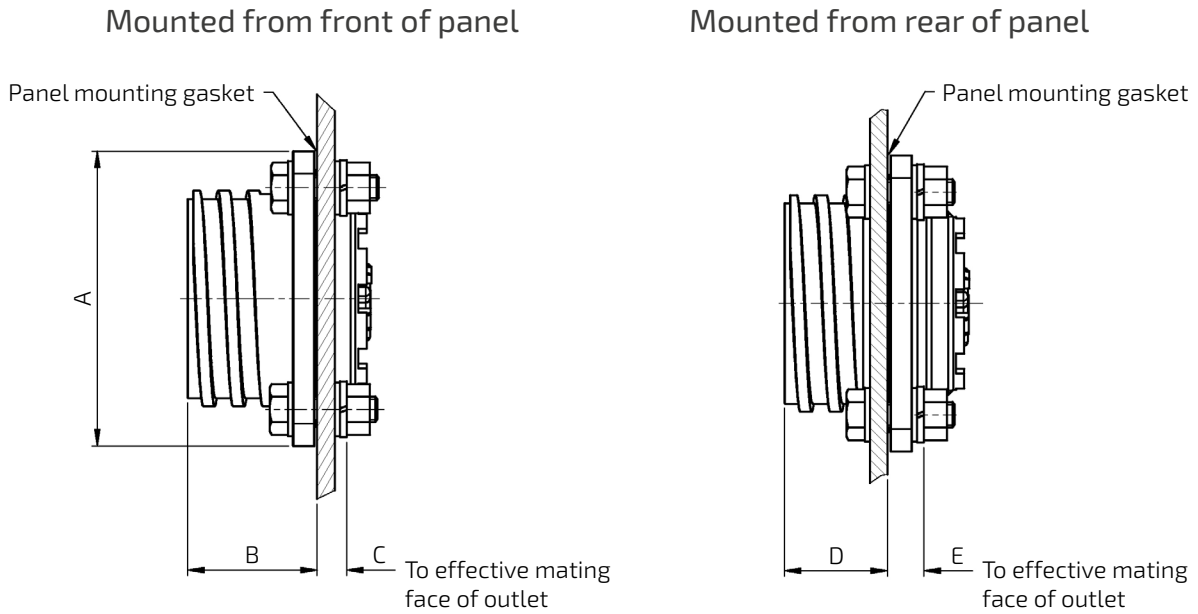

Shell size	A max	B nom	C nom	D max	E nom
1	Square 34.04	19.94	6.6	17.14	9.57
2	Square 42.16	19.94	6.6	17.14	9.57

Note: All dimensions are in millimeters (mm)

Connector Dimensions

Fixed Round Flange Plug and Socket Shell Styles

Mounted from front of panel

Outlets cannot be used

Mounted from rear of panel

Outlets may be used

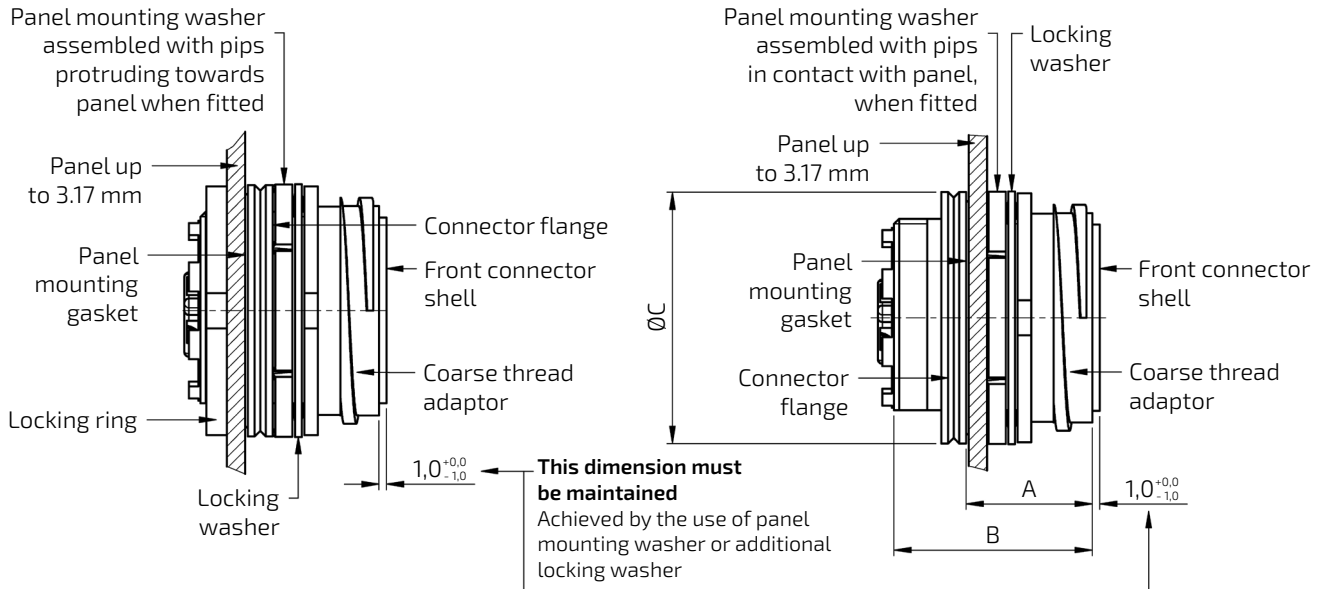

An additional locking washer is required for panels from 1.14 up to 2.16 mm
Use between panel and locking ring

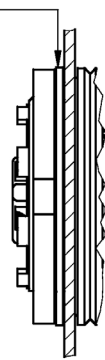

Alternatively for panels from 0.76 up to 1.14 mm use a panel mounting washer in between panel and locking ring

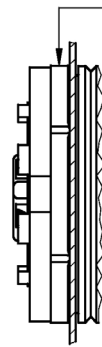

Shell size	A max	B nom	ØC nom	Panel mounting washer Part No.	Panel locking washer Part No.
1	15.24	25.65	29.21	LMA/2/07810/001	LMA/2/07549/001
2	15.24	25.65	34.80	LMA/2/07811/001	LMA/2/07550/001

For tool required when mounting see page 14.

For coupling thread see Free Unit on page 15.

Note: All dimensions are in millimeters (mm)

Connector Mounting Details

Panel piercing details for fixed square flange plug and socket shell styles

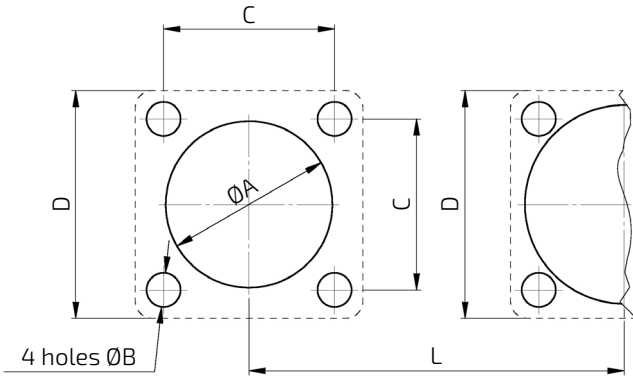

Corner bolt sealing details
Bolts should be mounted with bolt heads on the mating side of the connector

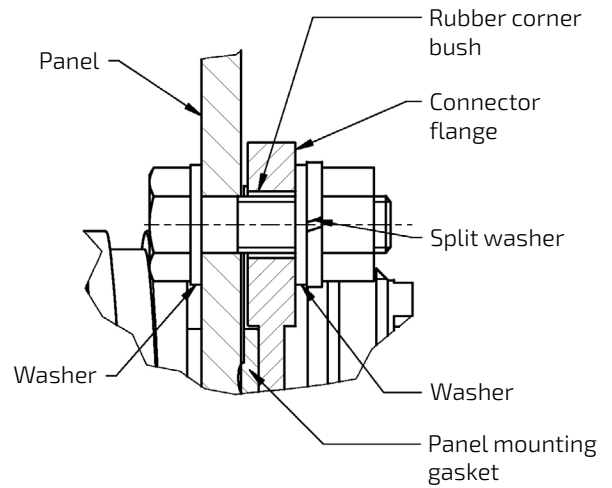

Shell size	ØA min/max		ØB nom	C 0.2	D nom	L nom
1	25.27	25.40	3.96	25.40	Square 33.78	36.83
2	30.86	30.99	5.10	31.37	Square 41.91	43.43

Panel piercing details for fixed round flange plug and socket shell styles

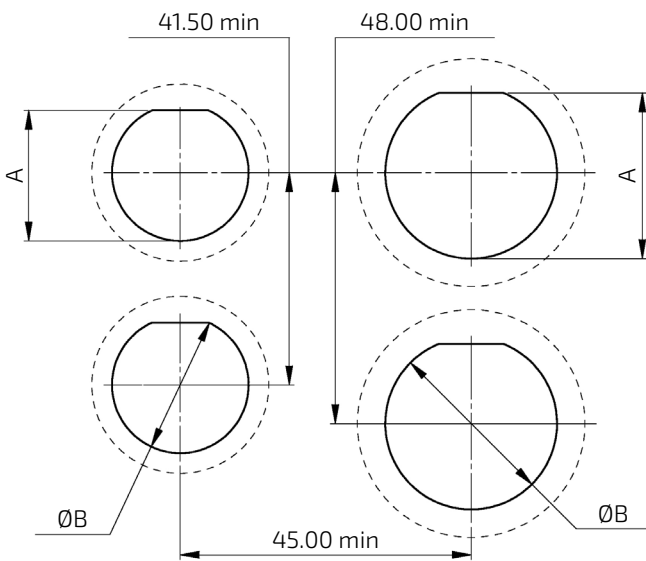

Shell size	A min/max	ØB nom
1	20.60/20.73	21.54/21.67
2	26.24/26.36	27.10/27.23

Note: All dimensions are in millimeters (mm)

Connector Wiring Instructions

Using Screened Multicore Cable

1. Strip outer sheath and braid. Thread onto cable - union nut (or cable clamp), packing piece, union gasket (see note), compression ring and cable sleeve. Comb out metal braid, fold back over outer sheath and tape down. Strip insulation 3.0 mm from conductors and tin. Thread on outlet nut, outlet and retaining gland.

NOTE: Union gasket must be a close fit to cable sheath. Synthetic rubber sleeves may be used to achieve required fit.

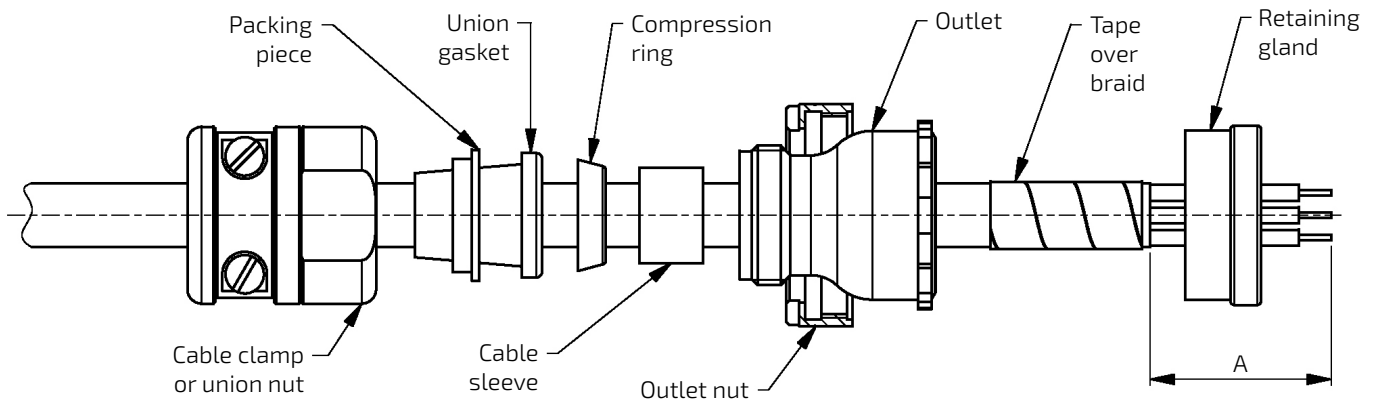

Shell size	Dimension A	
	Straight outlet	Angled outlet
Sheath	22.0	30.0
Braid	9.5	16.0

Continued on next page

Note: All dimensions are in millimeters (mm)

Connector Wiring Instructions

Using Screened Multicore Cable

2. Solder conductors to connector contacts:

- brown - **L**
- blue - **N**
- green/yellow - **E**

and slide retaining gland over joints.

Position outlet and secure with outlet nut.

Slide cable sleeve into neck of outlet.

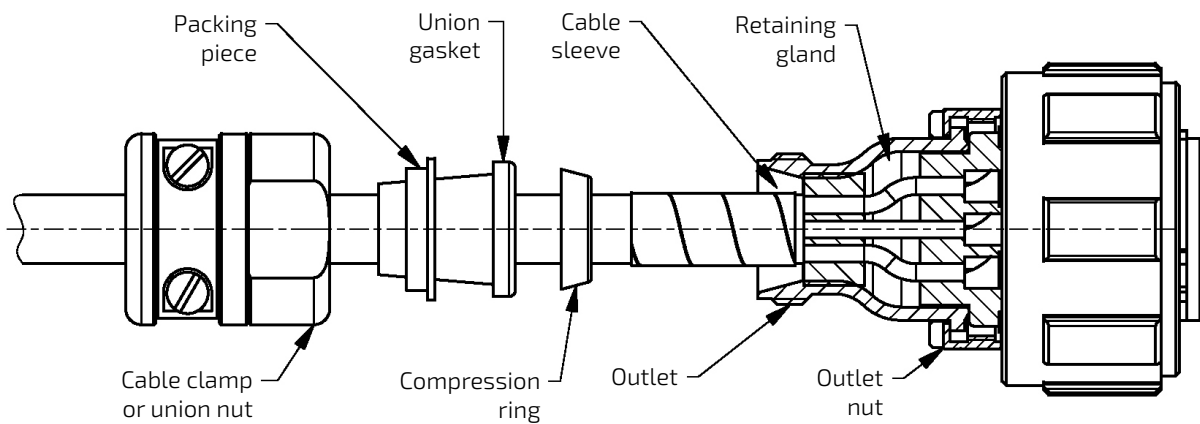

3. Remove tape from metal braid and fan out 90° to cable. Position compression ring on end of outer sheath, trapping braid between outlet and compression ring. Slide forward union gasket and packing piece to rear of compression ring. Trim off braid to rear face of compression ring and screw union nut (or clamp) onto outlet (tighten cable clamp, if used).

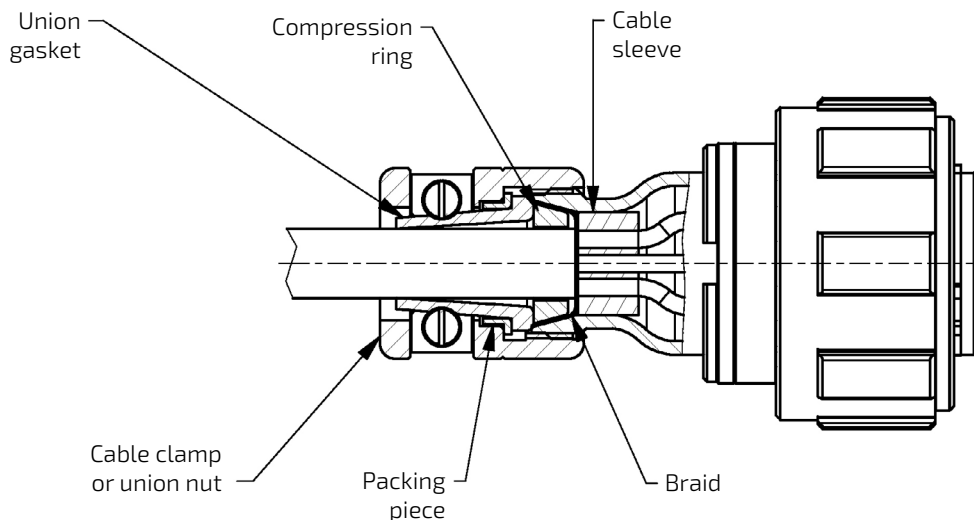

Connector Wiring Instructions

Using Unscreened Multicore Cable

1. Strip outer sheath as follows:

- Straight outlet dimensions 'A' 22.0 mm
- Right angle outlet dimension 'A' 30.0 mm
- Strip and tin each lead 3.0 mm

Thread on components in order shown.

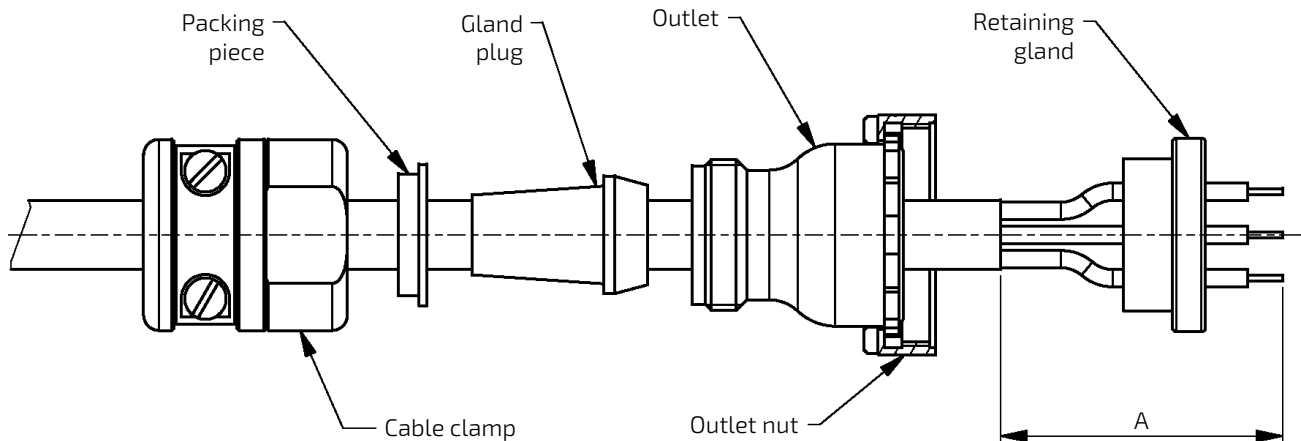

2. Solder conductors to connector contacts:

- brown - **L**
- blue - **N**
- yellow/green - **E**

Slide retaining gland forward over joints.

Position outlet and secure with outlet nut.

Slide gland plug into neck of outlet and screw on to outlet.

Screw down clamp jaw on to gland plug.

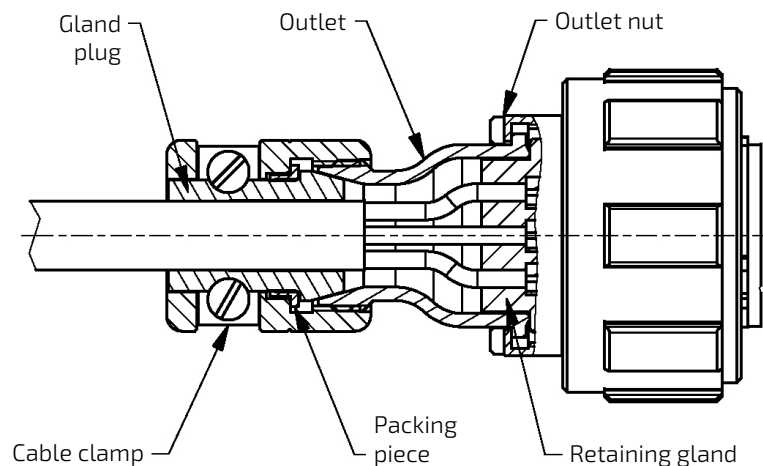

Connector Wiring Instructions

Earth Link Fitting Details

Earth Link is used in conjunction with outlet accessory sets to provide earth continuity to fixed and free bodies. To be fitted in accordance with instructions below and on packing label. Must be fitted to conform to the safety standards of CECC 75201-004.

Shell size 1 and shell size 2

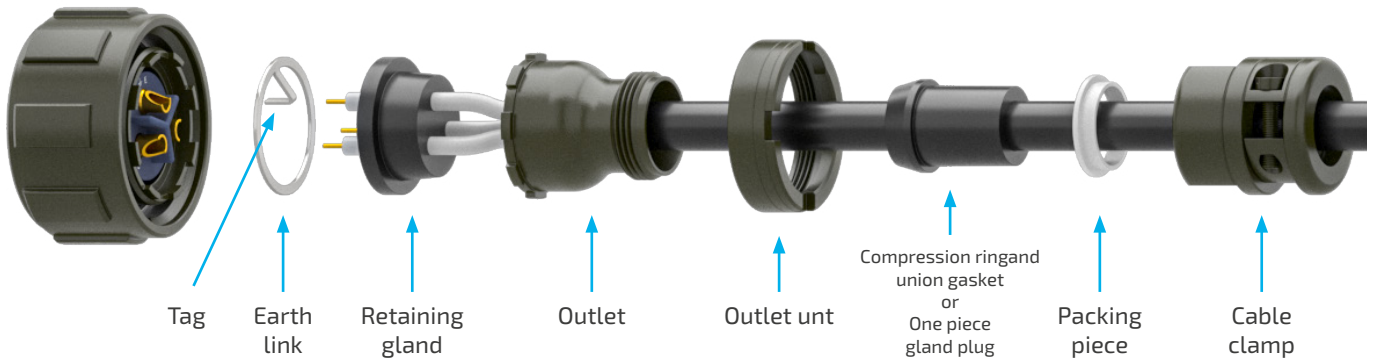

Earth link assembly details and fitting instructions:

1. Fit tag into solder bucket of earth terminal (E)
2. Ensure rim of earth link is seated into shell recess
3. Solder brown lead into live terminal (L)
4. Solder blue lead into neutral terminal (N)
5. Solder green/yellow lead and earth link tag into earth terminal (E)
6. Slide correctly orientated retaining gland firmly on to rim of earth link, assemble and tighten

IMPORTANT: Maintain pressure on the outlet to ensure that the castellations on the outlet and the connector are located before tightening the outlet nut.

Product Safety Information

These notes are intended to be used in conjunction with the Product Catalogue and Product Specification. Products may be safely used in the applications for which they have been designed and within the specified rating and environments. If products are exposed to conditions outside the performance ratings or specified environments they may constitute a hazard. In particular it should be noted that:

1. Material Content

Circular Connectors generally use metalwork parts made of brass, aluminium, phosphor-bronze or steel, which, dependant on the particular application, may be passivated and protected with cadmium or zinc plate – in conjunction with chromated or anodised surface finishes. The insulating materials can either be natural or synthetic rubber, together with plastic or glass-filled plastic moulded parts. Contact materials vary but are usually made of brass, phosphor-bronze, alumel or chromel.

2. Electric Shock, Burns and Fire

Hazard can occur if the product is used outside the specified parameters or if the product is damaged, wrongly wired, poorly assembled, poorly integrated into larger equipments, or contaminated with conductive fluids. Live circuit terminations must be protected and live circuits never broken by disconnecting products.

Hot spots may be created when resistance is increased due to damage or incorrect integration particularly soldering, or loose terminations. Overheating can cause breakdown of insulation, electric shock, burns or, ultimately, fire. In the event of fire noxious and/or toxic fumes may be released and, in these circumstances, any fire involving the product should be dealt with by personnel properly equipped. Connectors with exposed terminations or contacts should not be used on the current supply side of a circuit with exposed contacts on an unmated product. Before making a circuit live, the product and wiring should be checked to ensure there is no electrically conducting debris present. Circuit resistance checks should also be conducted before making the circuit live. Always ensure that connectors are assembled and wired by properly trained personnel.

3. Use, Transport and Storage of Products

Care must be exercised to avoid damage to any part of the products during transporting, storage or use. Abnormal transit or storage conditions and abuse during installation can give rise to damage. Products should not be used in a damaged condition.

Improper storage (particularly of damaged products) can give rise to additional hazards particularly corrosion. Attention is specifically drawn to the need for proper storage of products containing cadmium and you are advised to see the Guidance Note from the Health and safety Executive on Cadmium – Health and Safety Precautions.

4. Disposal of Products

Product should not be burnt.

Safety Rules

- Follow the guidelines given
- Always protect live circuits and never disconnect a live connector
- Never use a damaged connector
- Never burn discarded connectors

Lodge Group

FC Lane Electronics Ltd

Franchised connector distributor

+44 (0) 1403 790 661
fclane.com



Weald Electronics Ltd

Manufacturers of high quality connectors and accessories

+44 (0) 1403 790 715
wealdelectronics.com



Lane Motorsport

Division of FC Lane dedicated to motorsport industry

+44 (0) 1403 790 661
lanemotorsport.com

