



Miniature Bayonet Coupling Connector

Space saving with scoop proof connector for harsh applications.

A compact solution ■ Diameter up to 45% smaller than D38999 size 9.
Integrated backshell: up to 50% shorter.

A high density solution ■ With #26 contacts (according 39029).
6 layouts (size 3, 5 and 7 with #22 & #26).

Excellent features ■ Designed for D38999 requirements.
IP67 sealing when mated.

RoHS and Cadmium free ■ Available in zinc nickel (RoHS) plating, as well
as nickel and olive drab cadmium.

Not QPL listed.



Miniature sizes

- **A compact solution**
 - The smallest connector available on the market (shell size 3)
 - Miniaturization of MIL-DTL-38999 Series I
 - Quick bayonet locking
 - Integrated backshell:
 - . Easy to wire and handle
 - . Compatible with heat shrink boot and braid retention band
 - . Compliant with overmolding
- **A versatile solution**
 - 3 shell sizes (3, 5, 7), 5 shell types
 - 2 materials, 4 platings
 - Crimp & PC tails contacts
 - Removable contacts #22D & #26
 - 6 keyings
- **Harsh environment-resistant solution**
 - Scoop Proof
 - Cavity to cavity sealed with interfacial seal and grommet
 - Fluid resistant

Technical features

Mechanical

- **Shell:**
 - Aluminum alloy
 - Passivated stainless steel (for size 5 & 7)
- **Shell plating:**
 - Aluminum:
 - . Zinc nickel (RoHS)
 - . Nickel (RoHS)
 - . Olive drab cadmium
 - Passivated stainless steel (RoHS)
- **Insulator:** Thermoplastic
- **Contact body:** Copper alloy
- **Contacts plating:** Gold over nickel plated
- **Shell endurance:**
 - Aluminum:
 - 250 mating/unmating cycles
 - Passivated stainless steel:
 - 500 mating/unmating cycles
- **Vibration:**
 - 30 grms ambient, 2 axes during 8 hours

Electrical

- **Wire size**

Layouts	Wire (AWG)
03-05; 05-06; 07-09	24-30
03-35; 05-35; 07-35	22-28
- **Test voltage (at sea level):**
 - Size 22D: 1000 Vrms
 - Size 26: 400 Vrms
- **Contact resistance:**
 - Size 22D: <14.6 mΩ
 - Size 26: <16 mΩ
- **Contact rating:**
 - Size 22D: 5A
 - Size 26: 3A
- **Contact retention:**
 - Size 22D: 45N
 - Size 26: 30N
- **Shell to shell continuity (typical value)**

Shell size	All versions
3	250 mΩ
5	
7	
- **EMI:** -55dB @ 1GHz

Environmental

- **Temperature range:**
 - 55°C to +175°C
- **Water immersion:**
 - IP 67 on mated connector
 - 1 meter for 30 min minimum
 - > IP68 with appropriate cable termination
- **Salt spray:**
 - Zinc nickel: 500 hours
 - Nickel: 48 hours
 - Olive drab cadmium: 500 hours
 - Passivated stainless steel: 250 hours

Resistance to fluids

- **According to MIL-DTL-38999 standard**
 - Gasoline: JP5 (OTAN F44)
 - Mineral hydraulic fluid: MIL-H-5606 (OTAN H515)
 - Synthetic hydraulic fluid: Skydrol 500 B4
- **Compatible with de-icing fluids containing potassium acetate**

Shell types

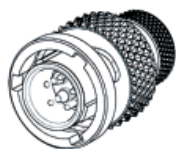

Plug



In line receptacle

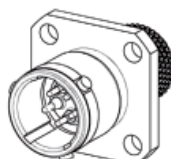

Square flange receptacle
(PC tail version available)

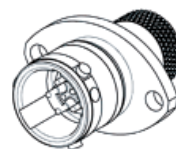

Oval flange receptacle
(PC tail version available)

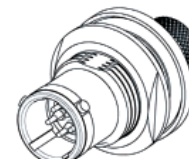

Jam nut receptacle
(PC tail version available)

For other configuration, please consult us.

Contact layouts

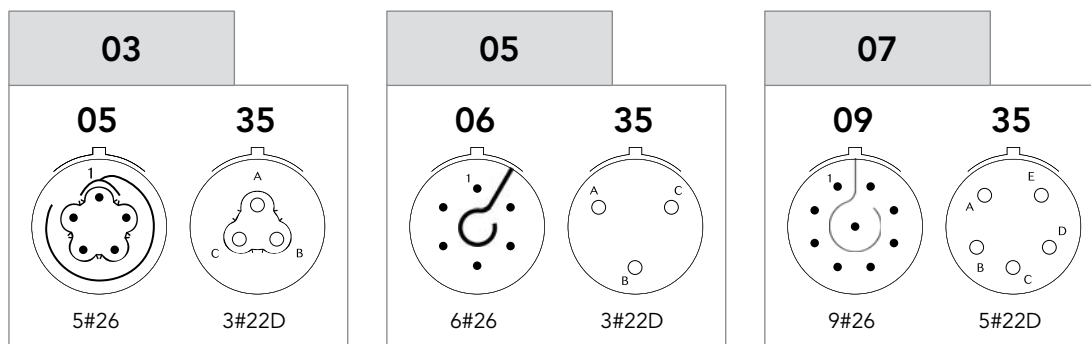

Size 3: Marking on shell.

Rear view of receptacle for male and female insulator. Opposite marking between plug and receptacle.

Sizes 5 and 7: Marking on insulator.

Rear view of male insulator for plug and receptacle. Opposite marking between male and female insulator.

Ordering information

Basic Series	8LTA	0	03	W	05	P	N
Shell type:							
0: Square flange receptacle							
1: In line receptacle							
2: Oval flange receptacle							
6: Plug without EMI ring							
7: Jam nut receptacle							
90: Square flange receptacle with PCB contacts							
92: Oval flange receptacle with PCB contacts							
97: Jam nut receptacle with PCB contacts							
Contact type:							
None: Standard crimp contacts							
C: Short PC tail							
L: Long PC tail (consult us)							
Shell size: 03, 05, 07							
Plating :							
Z: Black zinc nickel							
F: Nickel							
W: Olive drab cadmium							
K: Passivated stainless steel (only for sizes 05 & 07 with standard crimp contacts)							
Contact layouts: See above							
Contact type:							
P: Pin							
S: Socket - not available for PCB version							
Orientation: N, A, B, C, D, E (see page 8)							

Connector weights

Aluminum version - in gram $\pm 10\%$

Shell size & layout	Plug		In line receptacle	
	Without contacts	With crimp contacts	Without contacts	With crimp contacts
3-05	1.7	1.8	1.3	1.4
5-06	2.6	2.8	2.9	3.1
7-09	4.3	4.7	4.7	5.1

Dimensions

Plug - Shell type 6

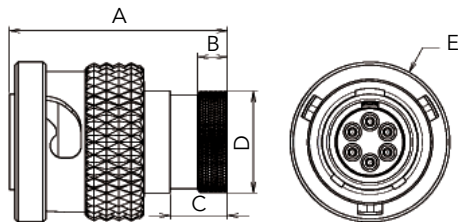

Shell size	A Max	B Max	C Max	ØD Max	ØE Max	
3	3-05	16.2	2.2 ± 0.15	4.6	7.2	10.5
	3-35	17.5	2.2 ± 0.15	5.9	7.2	10.5
05	18.4	2.5 ± 0.15	4.9	8.55	13.5	
07	22.06	3.65 ± 0.15	6.35	10.3	15.06	

In line receptacle - Shell type 1

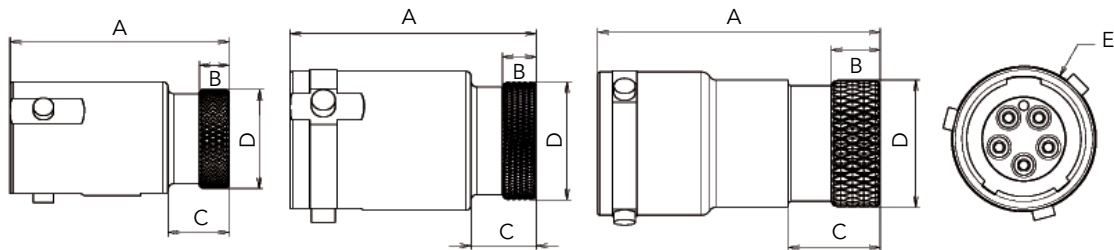

Shell size 3

Shell size 5

Shell size 7

Shell size	A Max	B Max	C Max	ØD Max	ØE Max	
3	3-05	16.2	2.2 ± 0.15	4.6	7.2	8.3
	3-35	17.5	2.2 ± 0.15	5.9	7.2	8.3
5	18.2	2.5 ± 0.15	4.9	8.55	10.15	
7	23.6	4 ± 0.15	7.5	10.3	11.6	

Note: All dimensions are in millimeters (mm)

Square flange receptacle - Shell type 0

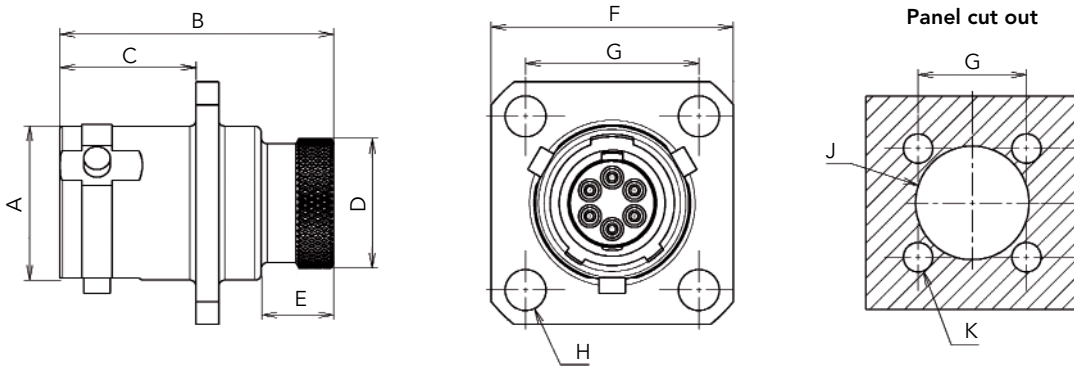

Shell size	ØA Max	B Max	C Max	ØD Max	E Max	F Max	G Max	ØH Max	ØJ Max	ØK Max	
3	3-05	8.3	16.2	8.7	7.2	4.6	15.5	10.8	2.7 ^{+0.1}	9.3 ^{+0.1}	3.1 ^{+0.1}
	3-35	8.3	17.5	8.7	7.2	5.9	15.5	10.8	2.7 ^{+0.1}	9.3 ^{+0.1}	3.1 ^{+0.1}
5	10.15	18.2	9.05	8.55	4.9	16	11.45	2.7 ^{+0.1}	12 ^{+0.1}	3.1 ^{+0.1}	
7	11.6	23.06	10.8	10.3	7.5	18	12.7	2.7 ^{+0.1}	13 ^{+0.1}	3.1 ^{+0.1}	

Square flange receptacle with PC tail contacts - Shell type 90

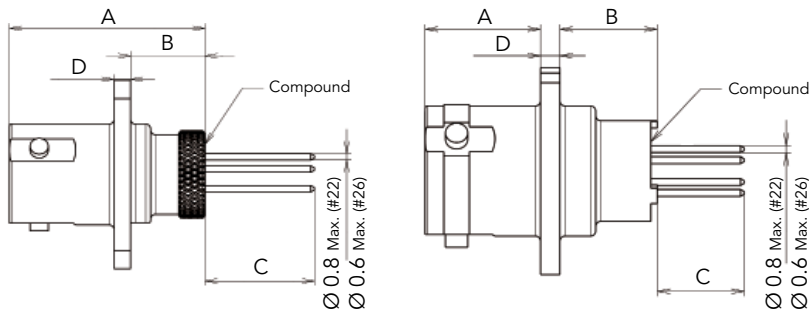

Shell size 3

Shell size 5 & 7

Layout	A Max.	B Max.	C Min.	C Max.	D Max.
03-05	16.4	6.35	8.75	9.49	1.65
03-35	17.7	7.75	7.40	8.19	1.65
05-06	9.25	7.85	6.54	7.34	1.80
05-35	9.25	7.85	6.47	7.19	1.80
07-09	13.05	7.35	5.80	6.62	2.35
07-35	13.05	7.35	5.53	6.52	2.35

Shell design vary according to shell size.
For L contact (long PC tail) please consult us.

Note: All dimensions are in millimeters (mm)

Oval flange receptacle - Shell type 2

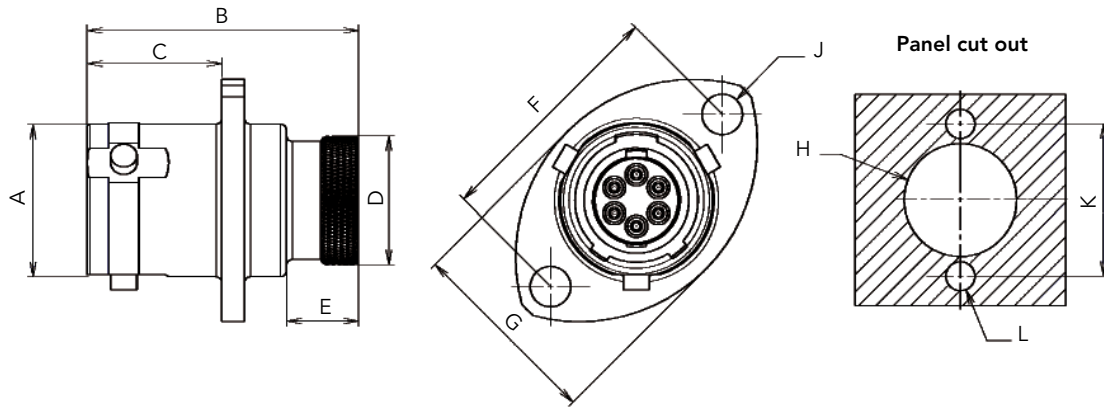

Shell size	ØA Max	B Max	C Max	ØD Max	E Max	F Max	G Max	ØH Max	ØJ Max	K Max	ØL Max	
3	3-05	8.3	16.2	8.7	7.2	4.6	15.3±0.2	10.5±0.1	2.8	9.3±0.1	15.3±0.2	3.1±0.1
	3-35	8.3	17.5	8.7	7.2	5.9	15.3±0.2	10.5±0.1	2.8	9.3±0.1	15.3±0.2	3.1±0.1
5	10.15	18.2	9.05	8.55	4.9	16.2±0.2	13±0.1	2.7	12±0.1	16.2±0.2	3.1±0.1	
7	11.6	23.06	10.8	10.3	7.5	18±0.2	14.8±0.1	2.7	13±0.1	18±0.2	3.1±0.1	

Oval flange receptacle with PC tail contacts - Shell type 92

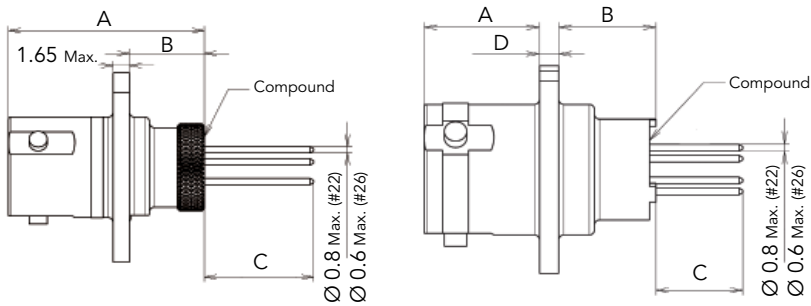

Shell size 3

Shell size 5 & 7

Layout	A Max.	B Max.	C Min.	C Max.	D Max.
03-05	16.2	6.35	8.75	9.49	-
03-35	17.5	7.75	7.4	8.19	-
05-06	9.25	7.85	6.54	7.34	1.80
05-35	9.25	7.85	6.47	7.19	1.80
07-09	13.05	7.35	5.8	6.62	2.35
07-35	13.05	7.35	5.53	6.52	2.35

Shell design vary according to shell size.
For L contact (long PC tail) please consult us.

Note: All dimensions are in millimeters (mm)

Jam nut receptacle - Shell type 7

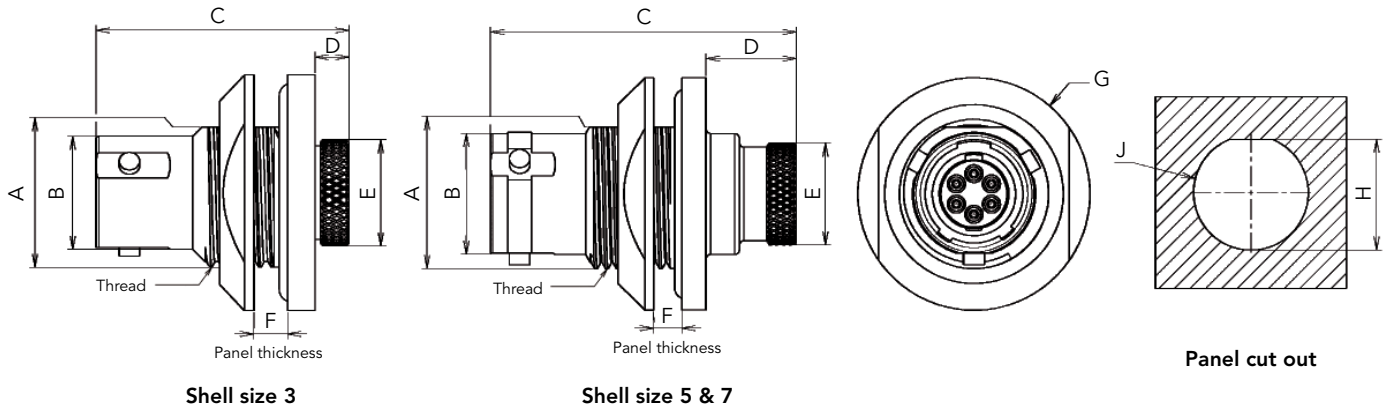

Shell size	Thread	A Max	ØB Max	C Max	D Max	ØE Max	F Max	ØG Max	H Max	ØJ Max	
3	3-05	7/16"28 UNEF 2A	10.3	8.3	16.2	2.6	7.8	1 to 3.2	17.3	11.3 ^{+0.1}	12 ^{±0.1}
	3-35	7/16"28 UNEF 2A	10.3	8.3	17.5	2.6	7.8	1 to 3.2	17.3	11.3 ^{+0.1}	12 ^{±0.1}
5	1/2"28 UNEF 2A	11.7	10.5	25.9	7.7	8.55	1 to 3.2	19.5	13 ^{+0.1}	13.5 ^{+0.1}	
7	9/16"24 UNEF 2A	13.4	11.6	33.55	10.4	10.3	1 to 3.2	20.8	14.4 ^{+0.1}	15.2 ^{±0.1}	

Jam nut receptacle with PC tail contacts - Shell type 97

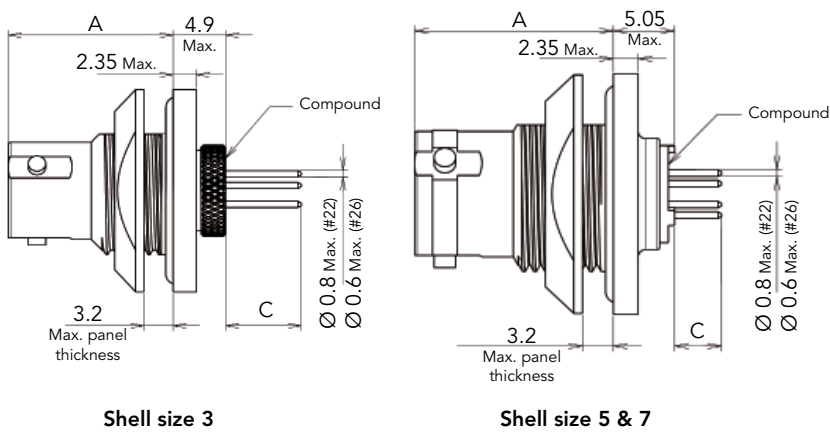

Layout	A Max.	Short PC tail C		Long PC tail L	
		C Min.	C Max.	C Min.	C Max.
03-05	14.4	6.15	7.04	10.65	11.54
03-35	15.7	4.8	5.7	9.3	10.19
05-06	16.4	3.54	4.52	7.99	9.02
05-35	16.4	3.42	4.33	7.92	8.83
07-09	21.3	4.05	5.07	7.60	8.57
07-35	21.3	3.79	4.93	7.29	8.43

Shell design vary according to shell size.

Note: All dimensions are in millimeters (mm)

Orientations

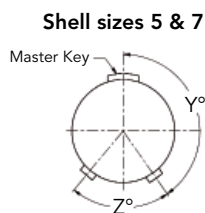
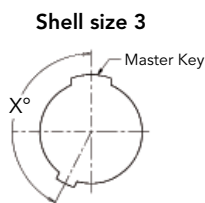

Shell size	Angles	N	A	B	C	D	E
3	X°	153	51	102	204	255	306
5 & 7	Y°	145	130	110	155	90	90
	Z°	75	120	120	115	115	180

Viewed from front face of plug

Aluminum caps

Basic Series	8LTAC	32	Z	03	N
Cap type:					
32: Cap for plug					
33: Cap for receptacle					
Plating:					
Z: Black zinc nickel					
F: Nickel					
W: Olive drab cadmium					
Shell size: 03, 05, 07					
Style:					
N: Ring					
R: Eyelet					

Gaskets

Shell size	Part number	
	Square flange	Oval flange
3	8LTA0G03	8LTA2G03
5	8LTA0G05	8LTA2G05
7	8LTA0G07	8LTA2G07

Dimensions

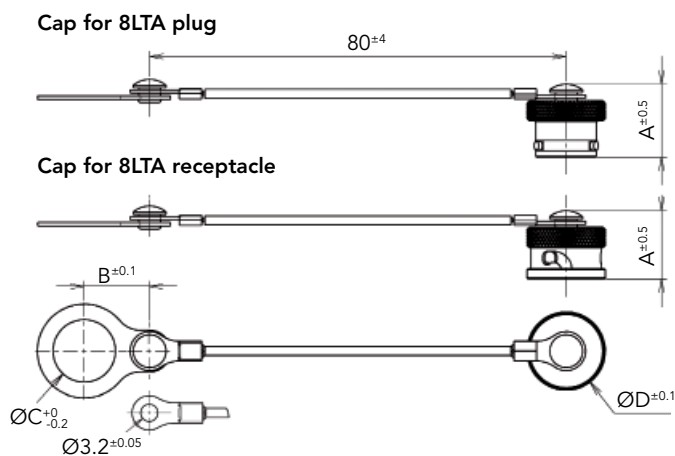

Shell size	A Plug	A Recep.	B	C	D
03	14.1	12.1	13.5	11.5	10.4
05	13.7	13.9	14.5	13	13.4
07	14	13.1	15.5	14.5	15.05

Note: for other lanyard length please consult us.

Note: All dimensions are in millimeters (mm)

For further information contact us at contactmilaero@souriau.com or visit our web site www.souriau.com