

LMV Connectors

MILITARY STYLE MAINS POWER CONNECTORS



www.weladelectronics.com

Weald
ELECTRONICS

MANUFACTURERS OF HIGH QUALITY MILITARY CIRCULAR CONNECTORS



**LMV RANGE
CONTENTS**



General information

Approvals 3
 Main features 3
 Intermateability 3
 Characteristics 4
 Connection system 4

Ordering information

Connectors 5
 Cable outlet accessory sets 6
 Protective caps 7, 8
 Earth link accessory sets 9
 Outlet nuts 9
 Fixing kits 9
 Assembly tools 9

Connector dimensions, panel piercing, mounting and sealing information

Free connectors 10
 Fixed square flange connectors 11
 Fixed round flange connectors 12

Wiring and assembly instructions

Connectors with screen terminations 13
 Connectors without screen terminations 14
 Earth link fitting details 14
 Product safety information 15

SAFETY

The performance of the connectors listed in this catalogue at all times exceeds the maximum continuous bunched rating of the appropriate size wire or cable of equivalent temperature rating, and this bunched rating shall be the determining factor. To achieve the BS CECC 75201-004 specification's standards of safety, the selected connector must be correctly assembled with the recommended outlet accessory set and earth link. For more details see pages 5 and 8.

It is recommended that a connector with socket/female contacts is wired to the power source and that the supply is always isolated before connection or disconnection. See Fig. 1 below.

The establishment of electrical safety factors is the responsibility of the user.

Fig. 1.

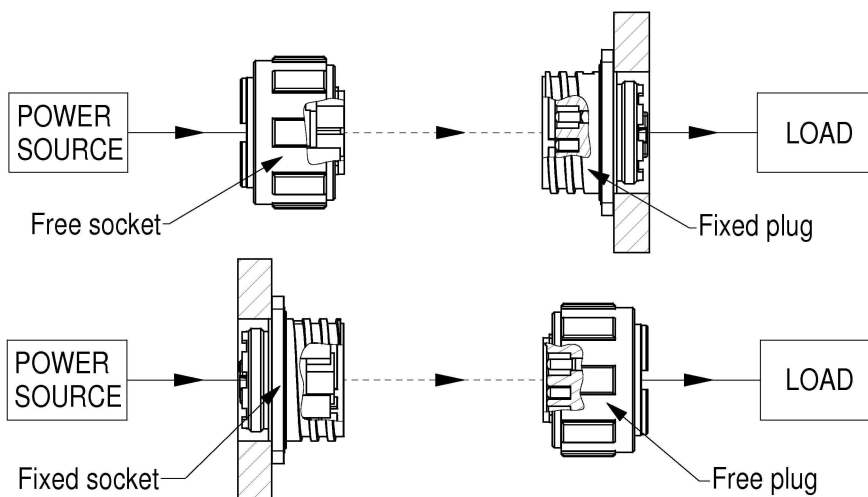

See page 15 for additional safety information



LMV RANGE GENERAL INFORMATION



Approved to BS CECC 75201-004 (which conforms to the safety requirements of BS EN 60950 for safe use in mains applications and CE marked equipment providing the connectors are used with the recommended Earth Link and outlet accessory sets).

LMV has been designed by Weald Electronics Ltd to provide a range of electrical connectors in various shell styles suitable for direct, 3 way mains connections in 250 volt AC or DC applications.

MAIN FEATURES

Connectors

- Special purpose connectors developed from the popular BS 9522 F0014 (LMG) range.
- Operating temperature range of -55°C to +100°C.
- Insert mouldings designed to give maximum surface tracking and clearance distances.
- Insert orientation normal 0 supplied as standard. Other orientations available as specials. Contact Sales Office for details.
- Finger probe proof live and neutral contacts provided with the safety of a leading earth contact.
- All contacts have solder terminations.
- Grounded shell to earth contact.
- 7.5 amp (shell size 1) and 20 amp (shell size 2) current ratings available.
- Connector styles: free plug or socket, fixed square or round flange plug or socket, cable coupler plug or socket.
- Shells are manufactured from brass and have a coarse, quick action coupling thread. Other special shell materials are available. Contact Sales Office for further information.
- Shells have a high resistance to corrosion and are supplied as standard with an olive drab chromate conversion over cadmium plate finish. Other special finishes are available. Contact Sales Office for further information.
- Fixed connectors are environment resistant with barrier and panel seals.
- Free connectors (including couplers) are environmentally resistant and barrier sealed.
- Contacts are finished with gold plate as standard.

Accessories

- Accessories are available to suit multi-core screened and unscreened cables.
- Backend accessory sets are available with straight or angled outlets terminating in either a union nut or cable clamp. Special retaining glands to prevent ingress of moisture are an integral part of these accessory sets.
- Connector shell and cable outlet, to earth contact 'link' accessory available.
- All metallic cable and protective cap accessory parts are manufactured from brass. Other materials are available as specials. Contact Sales Office for further information. Note: Brass accessories will only assemble with brass connectors as the product design changes with the material.

INTERMATEABILITY

LMV connectors will not intermate with Weald Electronics Ltd's LMF or LMG connector ranges. However, LMV connectors can be readily interchanged with shell size 1 or 2 LMF or LMG connector systems already installed in equipment that does not comply with the BS EN 60950 safety standards. Panel piercing and space envelopes are identical to sizes 1 & 2 LMF and LMG connectors.



**LMV RANGE
GENERAL INFORMATION**



CHARACTERISTICS

Environmental category	55/100/56												
Low pressure severity	300 mbar												
Temperature range	-55°C to +100°C In practice the temperature will be de-rated to that of the cable.												
Maximum current per contact through both live and neutral contacts simultaneously at 70°C ambient temperature	Size 1 connector 7.5 amps Size 2 connector 20 amps												
Working voltage dc or ac peak (sea level) Establishment of the electrical safety factors is the responsibility of the user	Size 1 connector 354 volts Size 2 connector 354 volt												
Voltage proof dc or ac peak	Size 1 connector 2000 volts Size 2 connector 2000 volts												
Number of contacts	3 (earth, live and neutral)												
Contact termination	Solder buckets												
Solder bucket bore diameter (max)	<table border="1"> <thead> <tr> <th></th> <th>Size 1</th> <th>Size 2</th> </tr> </thead> <tbody> <tr> <td>Earth</td> <td>1.75 mm</td> <td>2.75 mm</td> </tr> <tr> <td>Live</td> <td>1.40 mm</td> <td>2.75 mm</td> </tr> <tr> <td>Neutral</td> <td>1.40 mm</td> <td>2.75 mm</td> </tr> </tbody> </table>		Size 1	Size 2	Earth	1.75 mm	2.75 mm	Live	1.40 mm	2.75 mm	Neutral	1.40 mm	2.75 mm
	Size 1	Size 2											
Earth	1.75 mm	2.75 mm											
Live	1.40 mm	2.75 mm											
Neutral	1.40 mm	2.75 mm											
Contact finish	Gold plated												
Polarisation	By shell keys and keyways												
Insert orientation	Standard insert position 0 Special positions available												
Insert material	Polychloroprene and plastic												
Housing (Shell) material	Brass												
Housing (Shell) finish as standard (Special finishes available)	Olive drab chromate conversion over cadmium plate												
Sealing	Environmentally resistant with barrier or barrier and panel seal. Insert rated at 1cm ³ /hr max leakage at pressure differential of 1 bar												

SCHEMATIC SHOWING LMV CONNECTOR SYSTEM

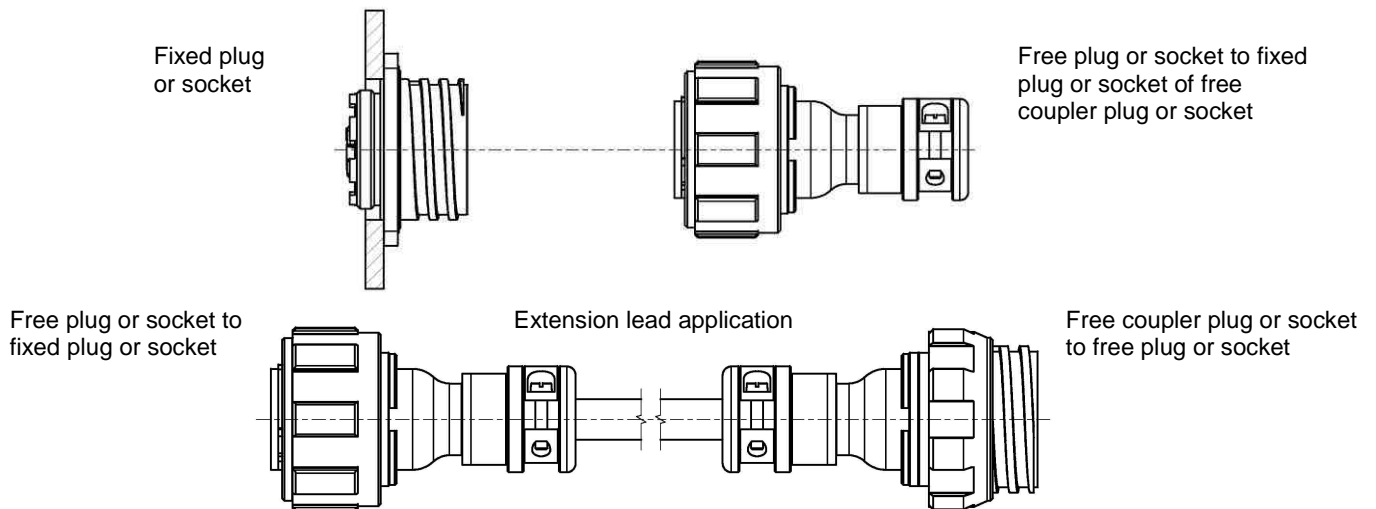

It is recommended that a connector with socket/female contacts is wired to the power source and that the supply is always isolated before connection or disconnection.



**LMV RANGE
CONNECTOR ORDERING INFORMATION**



FREE UNIT



	SIZE 1 7,5 amps 354 volts Weald Part No. / CECC Part No.	SIZE 2 20 amps 354 volts Weald Part No. / CECC Part No.
PLUG	LMV 2154-1M3-MO CECC 75201-004 C0103MS0 1 A 1H	LMV 2154-21M3-MO CECC 75201-004 C0203MS0 1 A 1H
SOCKET	LMV 2154-1M3-F0 CECC 75201-004 C0103FS0 1 A 1H	LMV 2154-21M3-F0 CECC 75201-004 C0203FS0 1 A 1H

A free unit is used to connect the cable to fixed units and free coupler units. Outlet nuts are supplied with these connectors

**FIXED UNIT
(Square Flange)**



	SIZE 1 7,5 amps 354 volts Weald Part No. / CECC Part No.	SIZE 2 20 amps 354 volts Weald Part No. / CECC Part No.
PLUG	LMV 2155-1M3-MO CECC 75201-004 A0103MS0 1 A 1H	LMV 2155-21M3-MO CECC 75201-004 A0203MS0 1 A 1H
SOCKET	LMV 2155-1M3-F0 CECC 75201-004 A0103FS0 1 A 1H	LMV 2155-21M3-MO CECC 75201-004 A0203FS0 1 A 1H

A fixed unit - four hole corner mounting - with the facility to accept cable accessory fittings. When these are required an outlet nut must be specified as an additional item.

**FREE
COUPLER UNIT**



	SIZE 1 7,5 amps 354 volts Weald Part No. / CECC Part No.	SIZE 2 20 amps 354 volts Weald Part No. / CECC Part No.
PLUG	LMV 2156-1M3-MO CECC 75201-004 D0103MS0 1 A 1H	LMV 2156-21M3-MO CECC 75201-004 D0203MS0 1 A 1H
SOCKET	LMV 2156-1M3-F0 CECC 75201-004 D0103FS0 1 A 1H	LMV 2156-21M3-F0 CECC 75201-004 D0203FS0 1 A 1H

A free coupler unit is used as a means of connecting two free cables and mates with the free units only. Outlet nuts are supplied with these connectors.

**FIXED UNIT
(Round Flange)**



	SIZE 1 7,5 amps 354 volts Weald Part No. / CECC Part No.	SIZE 2 20 amps 354 volts Weald Part No. / CECC Part No.
PLUG	LMV 2157-1M3-MO CECC 75201-004 B0103MS0 1 A 1H	LMV 2157-21M3-MO CECC 75201-004 B0203MS0 1 A 1H
SOCKET	LMV 2157-1M3-F0 CECC 75201-004 B0103FS0 1 A 1H	LMV 2157-21M3-F0 CECC 75201-004 B0203FS0 1 A 1H

A fixed unit - single hole mounting - with the facility to accept cable accessory fittings. When these are required an outlet nut must be specified as an additional item.



LMV RANGE OUTLET ACCESSORY SETS ORDERING INFORMATION



UNSCREENED MULTICORE CABLE

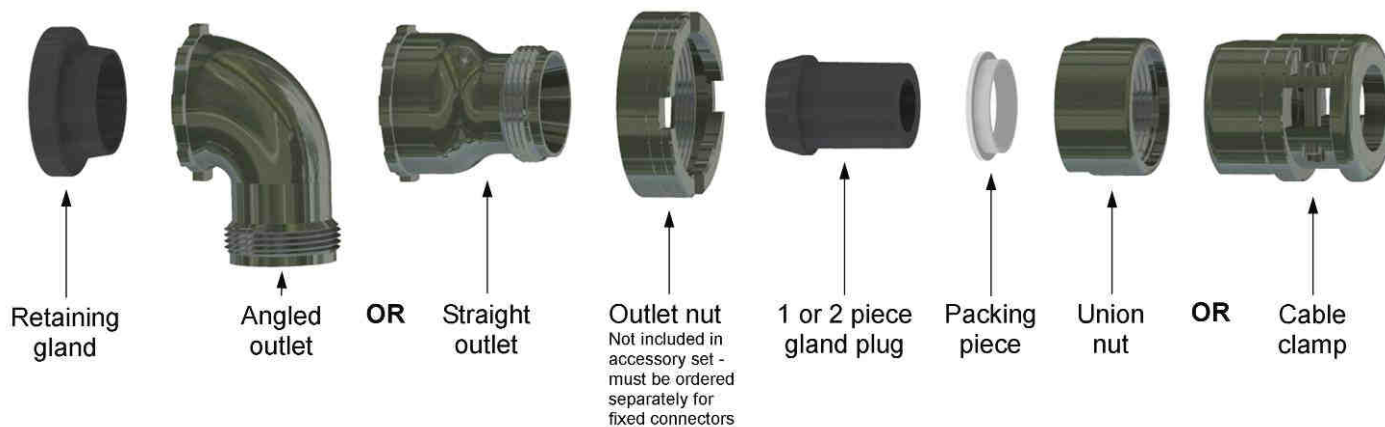

			SIZE 1 Cable O/D 6.4 Min, 8.0 Max (mm)	SIZE 2 Cable O/D 7.5 Min, 10.2 Max (mm)
Outlet Accessory Set with Union Nut	Straight Outlet	Weald Pt. No.	LMA/1/41507/201	LMA/1/41534/201
		CECC Pt. No.	CECC 75201-004 A01 A A	CECC 75201-004 A02 A A
	Rt. Angled Outlet	Weald Pt. No.	LMA/1/41509/201	LMA/1/41535/201
		CECC Pt. No.	CECC 75201-004 A01 B A	CECC 75201-004 A02 B A
Outlet Accessory Set with Cable Clamp	Straight Outlet	Weald Pt. No.	LMA/1/41508/201	LMA/1/41536/201
		CECC Pt. No.	CECC 75201-004 A01 C A	CECC 75201-004 A02 C A
	Rt. Angled Outlet	Weald Pt. No.	LMA/1/41510/201	LMA/1/41537/201
		CECC Pt. No.	CECC 75201-004 A01 D A	CECC 75201-004 A02 D A

MULTICORE CABLE WITH INNER COLLECTIVE SCREEN ONLY

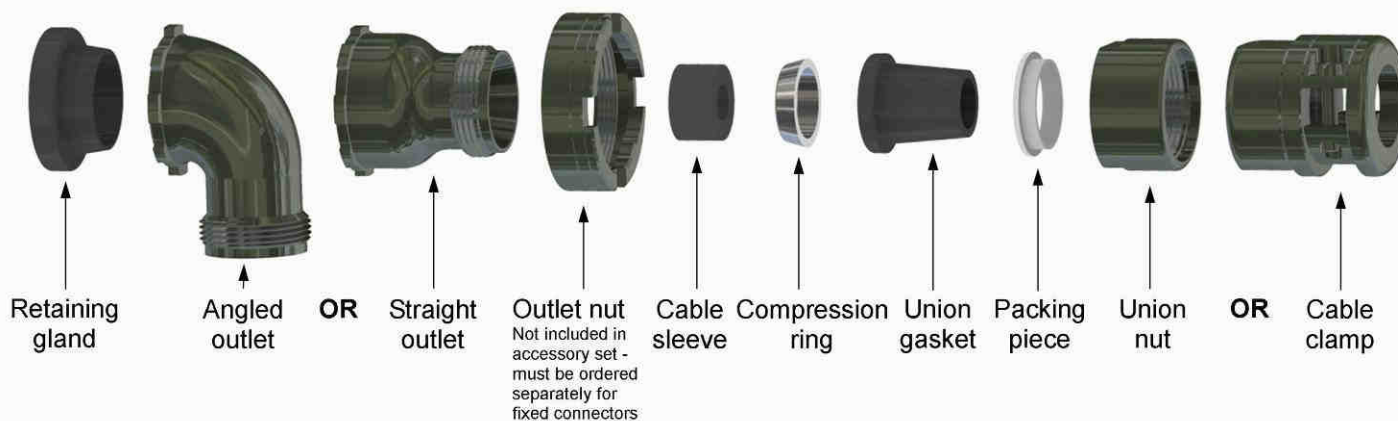

			SIZE 1 Cable O/D 6.15 Min, 7.65 Max (mm)	SIZE 2 Cable O/D 7.5 Min, 10.2 Max (mm)
Outlet Accessory Set with Union Nut	Straight Outlet	Weald Pt. No.	LMA/1/41513/201	LMA/1/41538/201
		CECC Pt. No.	CECC 75201-004 A01 E A	CECC 75201-004 A02 E A
	Rt. Angled Outlet	Weald Pt. No.	LMA/1/41515/201	LMA/1/41539/201
		CECC Pt. No.	CECC 75201-004 A01 F A	CECC 75201-004 A02 F A
Outlet Accessory Set with Cable Clamp	Straight Outlet	Weald Pt. No.	LMA/1/41514/201	LMA/1/41540/201
		CECC Pt. No.	CECC 75201-004 A01 G A	CECC 75201-004 A02 G A
	Rt. Angled Outlet	Weald Pt. No.	LMA/1/41516/201	LMA/1/41541/201
		CECC Pt. No.	CECC 75201-004 A01 H A	CECC 75201-004 A02 H A



**LMV RANGE
PROTECTIVE CAPS ORDERING INFORMATION**



**PROTECTIVE CAPS FOR FREE PLUGS OR SOCKETS
AVAILABLE IN MACHINED BRASS OR MOULDED MDPE (MEDIUM DENSITY POLYETHYLENE)**



	SIZE 1 Weald Part No. / CECC Part No.	SIZE 2 Weald Part No. / CECC Part No.
Ball chain assembly MDPE moulded cap	LMA/1/41150/001	LMA/1/41153/001
	CECC 75201-004 B01 A A	CECC 75201-004 B02 A A
Nylon cord assembly MDPE moulded cap	LMA/1/41092/001	LMA/1/41095/001
	CECC 75201-004 B01 B A	CECC 75201-004 B02 B A
Screw on MDPE moulded cap only	LMA/2/41172	LMA/2/41173
	CECC 75201-004 B01 C	CECC 75201-004 B02 C
Link chain assembly machined brass cap	LMA/1/04111/001	LMA/1/04112/001
	CECC 75201-004 B01 D A	CECC 75201-004 B02 D A
Nylon cord assembly machined brass cap	LMA/1/04139/001	LMA/1/04140/001
	CECC 75201-004 B01 E A	CECC 75201-004 B02 E A

**PROTECTIVE CAPS FOR FREE COUPLER PLUGS OR SOCKETS
AVAILABLE IN MACHINED BRASS OR MOULDED MDPE (MEDIUM DENSITY POLYETHYLENE)**



	SIZE 1 Weald Part No. / CECC Part No.	SIZE 2 Weald Part No. / CECC Part No.
Ball chain assembly MDPE moulded cap	LMA/1/04119/001	LMA/1/04120/001
	CECC 75201-004 B01 F A	CECC 75201-004 B02 F A
Nylon cord assembly MDPE moulded cap	LMA/1/04129/001	LMA/1/04130/001
	CECC 75201-004 B01 G A	CECC 75201-004 B02 G A
Screw on MDPE moulded cap only	LMA/2/41181	LMA/2/41182
	CECC 75201-004 B01 H	CECC 75201-004 B02 H
Link chain assembly machined brass cap	LMA/1/04124/001	LMA/1/04125/001
	CECC 75201-004 B01 J A	CECC 75201-004 B02 J A
Nylon cord assembly machined brass cap	LMA/1/04134/001	LMA/1/04135/001
	CECC 75201-004 B01 K A	CECC 75201-004 B02 K A



**LMV RANGE
PROTECTIVE CAPS ORDERING INFORMATION**



**PROTECTIVE CAPS FOR FIXED SQUARE PLUGS OR SOCKETS
AVAILABLE IN MACHINED BRASS OR MOULDED MDPE (MEDIUM DENSITY POLYETHYLENE)**



	SIZE 1 Weald Part No. / CECC Part No.	SIZE 2 Weald Part No. / CECC Part No.
Ball chain assembly MDPE moulded cap	LMA/1/41160/001	LMA/1/41161/001
	CECC 75201-004 B01 L A	CECC 75201-004 B02 L A
Nylon cord assembly MDPE moulded cap	LMA/1/41132/001	LMA/1/41133/001
	CECC 75201-004 B01 M A	CECC 75201-004 B02 M A
Screw on MDPE moulded cap only	LMA/2/41181	LMA/2/41182
	CECC 75201-004 B01 H	CECC 75201-004 B02 H
Link chain assembly machined brass cap	LMA/1/04116/001	LMA/1/04117/001
	CECC 75201-004 B01 P A	CECC 75201-004 B02 P A
Nylon cord assembly machined brass cap	LMA/1/04226/001	LMA/1/04227/001
	CECC 75201-004 B01 R A	CECC 75201-004 B02 R A

**PROTECTIVE CAPS FOR FIXED ROUND FLANGE PLUGS OR SOCKETS
AVAILABLE IN MACHINED BRASS OR MOULDED MDPE (MEDIUM DENSITY POLYETHYLENE)**



	SIZE 1 Weald Part No. / CECC Part No.	SIZE 2 Weald Part No. / CECC Part No.
Ball chain assembly MDPE moulded cap	LMA/1/41198/001	LMA/1/41199/001
	CECC 75201-004 B01 S A	CECC 75201-004 B02 S A
Nylon cord assembly MDPE moulded cap	LMA/1/41201/001	LMA/1/41202/001
	CECC 75201-004 B01 T A	CECC 75201-004 B02 T A
Screw on MDPE moulded cap only	LMA/2/41181	LMA/2/41182
	CECC 75201-004 B01 H	CECC 75201-004 B02 H
Link chain assembly machined brass cap	LMA/1/41208/001	LMA/1/41209/001
	CECC 75201-004 B01 V A	CECC 75201-004 B02 V A
Nylon cord assembly machined brass cap	LMA/1/41211/001	LMA/1/41212/001
	CECC 75201-004 B01 W A	CECC 75201-004 B02 W A



LMV RANGE
ACCESSORIES ORDERING INFORMATION



EARTH LINK

Used in conjunction with outlet accessory sets to provide earth continuity to fixed and free bodies. To be fitted in accordance with instructions on page 14 & on packing label. Must be fitted to conform to the safety standards of CECC 75201-004



	SHELL SIZE 1	SHELL SIZE 2
Weald Part No.	LMA/1/80020/015	LMA/1/80269/015
CECC Part No.	CECC 75201-004 A 01 L	CECC 75201-004 A 02 L

OUTLET NUT

For fixed square flange connectors.



	SHELL SIZE 1	SHELL SIZE 2
Weald Part No.	LMA/2/07569/001	LMA/2/07570/001
CECC Part No.	CECC 75201-004 A 01 J A	CECC 75201-004 A 02 J A

FIXING KITS FOR SQUARE FLANGE CONNECTORS

These kits contain the necessary nuts, bolts, washers and bushes that are required for panel mounting square flange style LMV connectors.

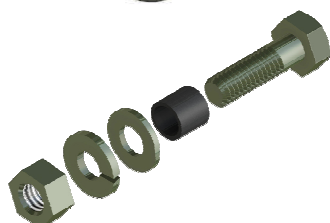

	SHELL SIZE 1	SHELL SIZE 2
Weald Part No.	LMA/1/07615/001	LMA/1/07616/001

ASSEMBLY TOOLS ORDERING INFORMATION

Tools required for locking cable entry fittings and for mounting fixed units to panels

SPECIAL SPANNER

Used on fixed units to facilitate tightening of panel locking rings.

	SHELL SIZE 1	SHELL SIZE 2
Weald Part No.	LMT/2/00574	LMT/2/00575
CECC Part No.	CECC 75201-004 C 01 A E	CECC 75201-004 C 02 A E



TOMMY BAR

Used with special spanner (as shown).

	SHELL SIZE 1	SHELL SIZE 2
Weald Part No.	LMT/2/00573	LMT/2/00573
CECC Part No.	CECC 75201-004 C 00 D E	CECC 75201-004 C 00 D E



DOUBLE ENDED SPANNER

Used in conjunction with body holder to facilitate tightening of outlet nuts and panel locking rings.

	SHELL SIZE 1	SHELL SIZE 2
Weald Part No.	LMT/2/00564	LMT/2/00565
CECC Part No.	CECC 75201-004 C 01 C E	CECC 75201-004 C 02 C E



BODY HOLDER

Used in conjunction with double ended spanner - locates on front face of connectors.

	SHELL SIZE 1	SHELL SIZE 2
Weald Part No.	LMT/2/00261	LMT/2/00262
CECC Part No.	CECC 75201-004 C 01 B E	CECC 75201-004 C 02 B E



**LMV RANGE
CONNECTOR DIMENSIONS**



DIMENSIONS FOR FREE PLUG AND FREE SOCKET STYLES

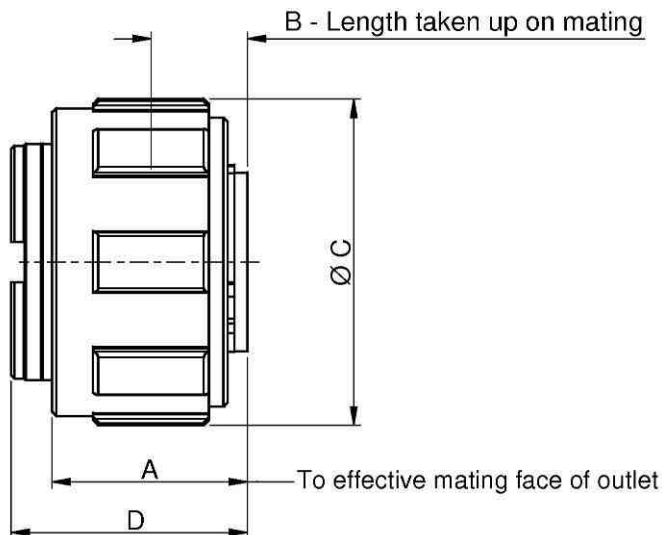

Shell Size	A mm max	B mm max	C dia. mm max	D mm max	Coupling thread dia. x6 TPI modified Acme
1	22.61	8.00	32.51	26.67	Nominal major 25.40mm
2	22.61	8.00	38.61	26.67	Nominal major 30.96mm

DIMENSIONS FOR FREE COUPLER PLUG AND FREE SOCKET STYLES

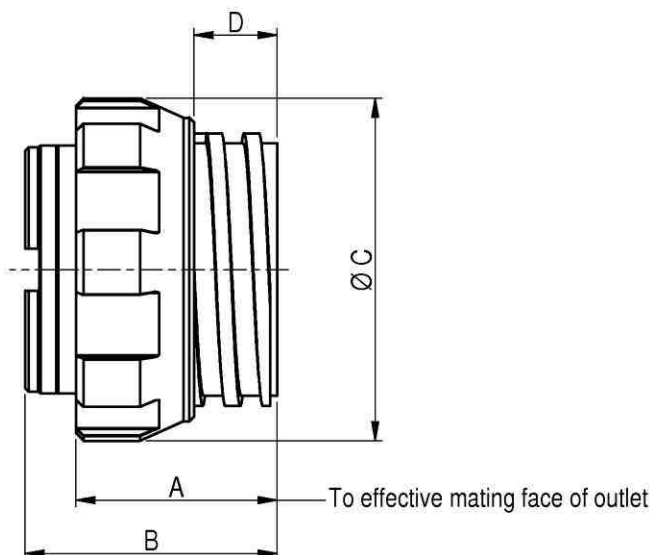

Shell Size	A mm max	B mm max	C dia. mm max	D mm max	Coupling thread dia. x6 TPI modified Acme
1	26.92	30.48	32.51	12.00	Nominal major 25.40mm
2	26.92	30.48	38.61	12.00	Nominal major 30.96mm



LMV RANGE CONNECTOR DIMENSIONS AND MOUNTING INFORMATION



FIXED SQUARE FLANGE PLUG AND SOCKET SHELL STYLES

Supplied complete with panel mounting gasket, corner bushes, nuts, bolts and washers. Bolts should be mounted with bolt heads on the mating side of the connectors. Lengths of bolts are dependent upon panel thickness. With those supplied max. panel thickness is 3.18mm.

MOUNTED FROM FRONT OF PANEL

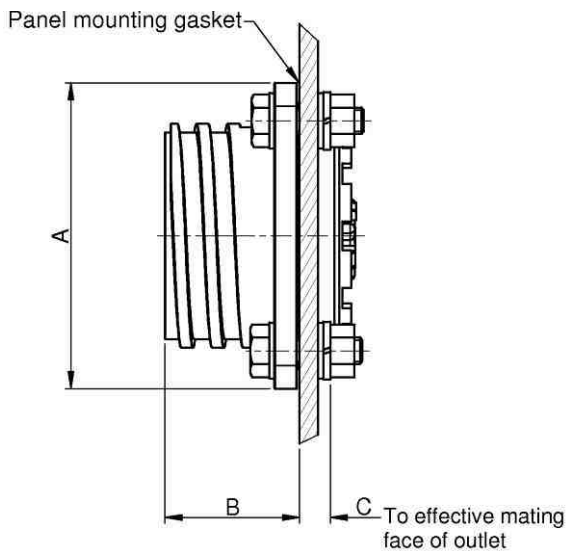

MOUNTED FROM REAR OF PANEL

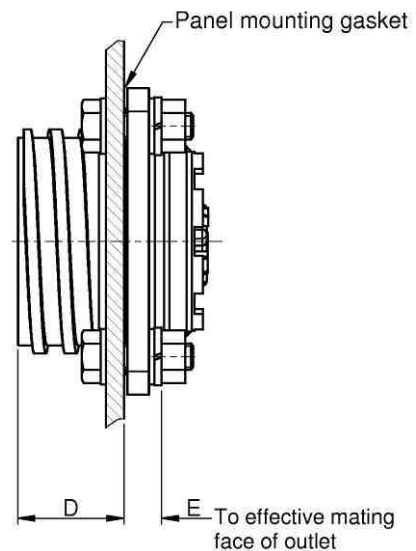

Shell Size	A mm max	B mm nom	C mm nom	D mm max	E mm nom
1	Square 34.04	19.94	6.6	17.14	9.57
2	Square 42.16	19.94	6.6	17.14	9.57

PANEL PIERCING DETAILS FOR FIXED SQUARE FLANGE PLUG AND SOCKET SHELL STYLES

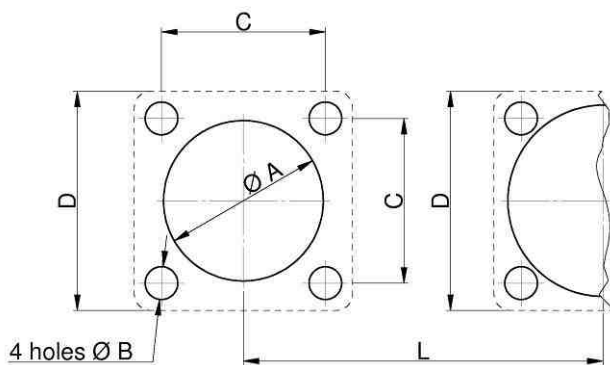

CORNER BOLT SEALING DETAILS

Bolts should be mounted with bolt heads on the mating side of the connector.

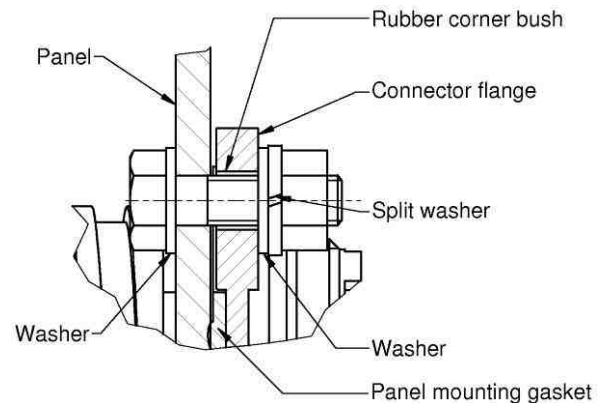

Shell Size	A mm dia. min/max		B mm dia. nom	C mm 0.2	D mm nom.	L mm nom
1	25.27	25.4	3.96	25.4	Square 33.78	36.83
2	30.86	30.99	5.10	31.37	Square 41.91	43.43



LMV RANGE
CONNECTOR DIMENSIONS AND MOUNTING INFORMATION



FIXED ROUND FLANGE PLUG AND SOCKET SHELL STYLES

MOUNTED FROM FRONT OF PANEL
Outlets cannot be used

MOUNTED FROM REAR OF PANEL
Outlets may be used

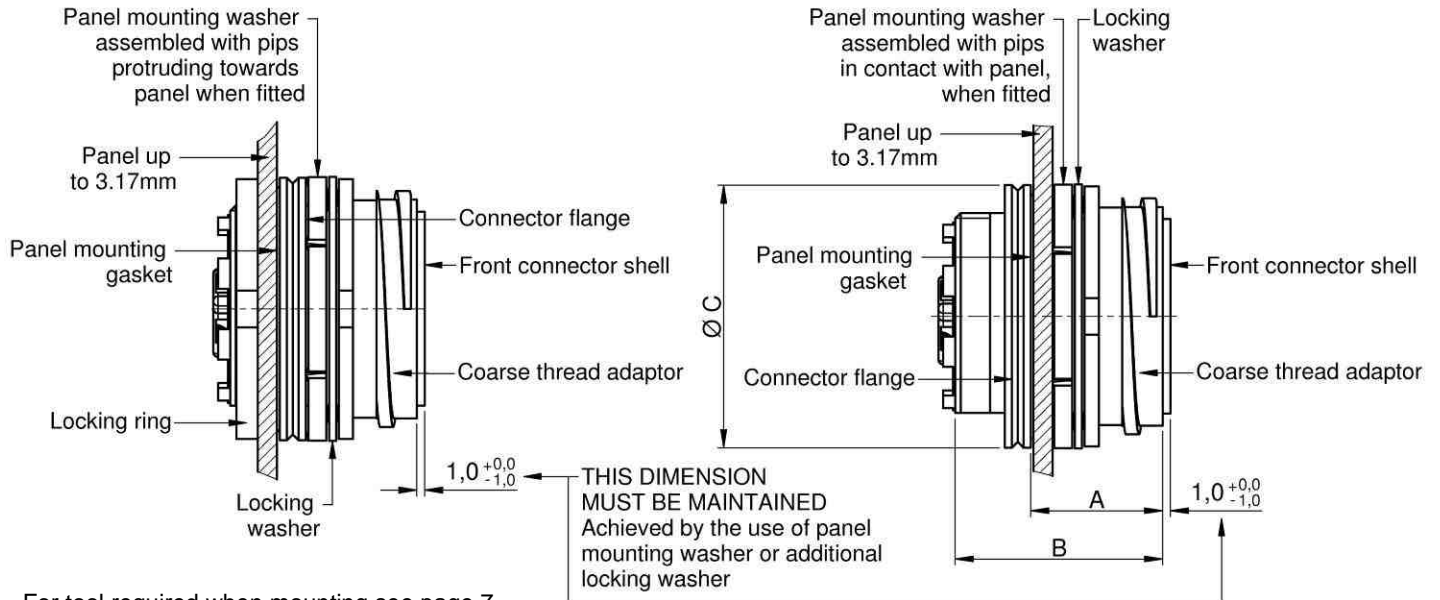

For tool required when mounting see page 7.
For coupling thread see Free Unit (Page 8).

Shell Size	A mm	B mm	C mm	Panel mounting washer Pt. No.	Panel locking washer Pt. No.
1	15.24	25.65	29.21	LMA/2/07810/001	LMA/2/07549/001
2	15.24	25.65	34.8	LMA/2/07811/001	LMA/2/07550/001

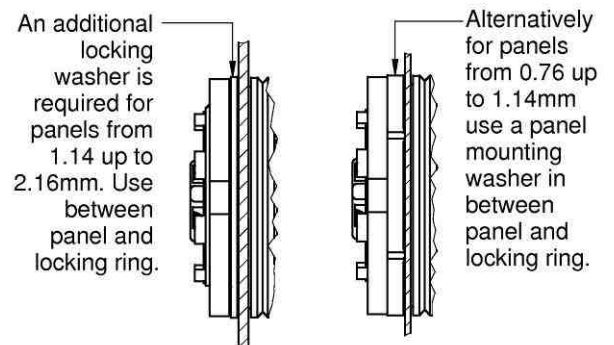

PANEL PIERCING DETAILS FOR FIXED ROUND FLANGE PLUG AND SOCKET SHELL STYLES

Shell Size	A mm min/max	B mm dia. nom
1	20.60/20.73	21.54/21.67
2	26.24/26.36	27.10/27.23

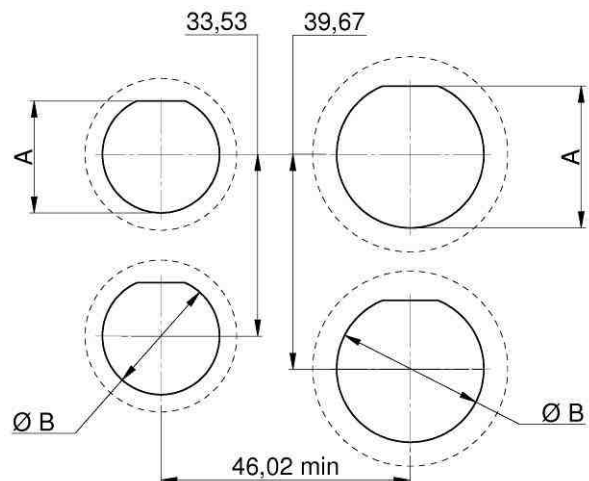



LMV RANGE CONNECTOR WIRING INSTRUCTIONS



USING MULTICORE CABLE WITH INNER COLLECTIVE SCREEN

- Strip outer sheath and braid. Thread onto cable - union nut (or cable clamp), packing piece, union gasket (see note), compression ring and cable sleeve. Comb out metal braid, fold back over outer sheath and tape down. Strip insulation 3.0mm from conductors and tin. Thread on outlet nut, outlet and retaining gland.

NOTE:

Union gasket must be a close fit to cable sheath. Synthetic rubber sleeves may be used to achieve required fit.

	Dimension A mm	
	Straight Outlet	Straight Outlet
Sheath	22.0	30.0
Braid	9.5	16.0

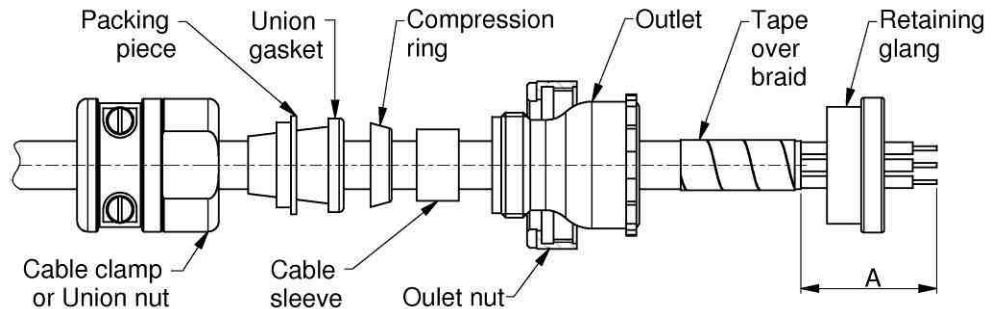

- Solder conductors to connector contacts, - brown - L, blue - N, green/yellow - E and slide retaining gland over joints. Position outlet and secure with outlet nut. Slide cable sleeve into neck of outlet.

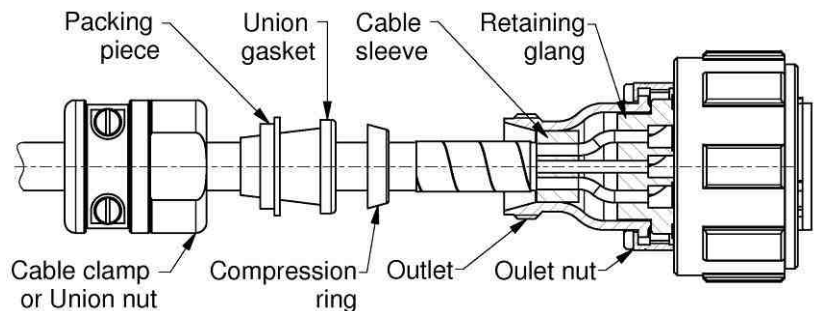

- Remove tape from metal braid and fan out 90° to cable. Position compression ring on end of outer sheath, trapping braid between outlet and compression ring. Slide forward union gasket and packing piece to rear of compression ring. Trim off braid to rear face of compression ring and screw union nut (or clamp) onto outlet. (Tighten cable clamp, if used.)

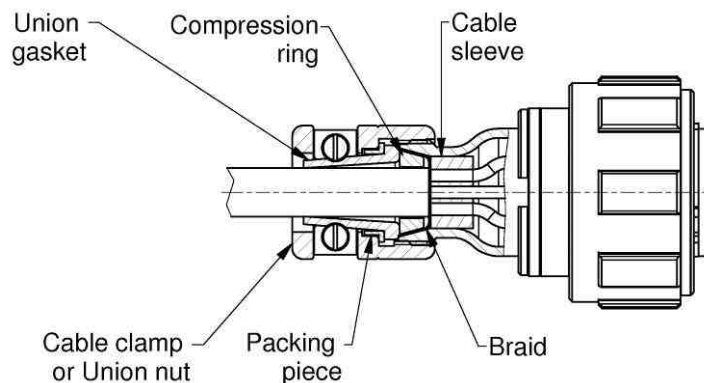



LMV RANGE CONNECTOR WIRING INSTRUCTION



USING MULTICORE CABLE TOTALLY UNSCREENED

- Strip outer sheath as follows:
Straight outlet dimensions 'A' 22.0mm
Right angle outlet dimension 'A' 30mm
Strip and tin each lead 3.0mm
Thread on components in order shown.

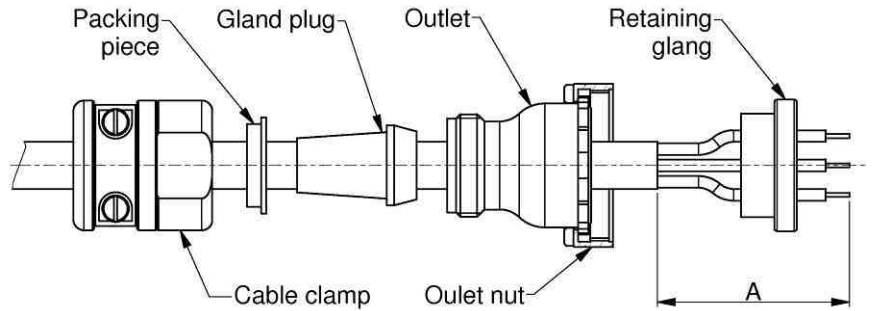

- Solder conductors to connector contacts
brown - L, blue - N, yellow/green - E.
Slide retaining gland forward over joints.
Position outlet and secure with outlet nut.
Slide gland plug into neck of outlet and screw on to outlet.
Screw down clamp jaw on to gland plug.

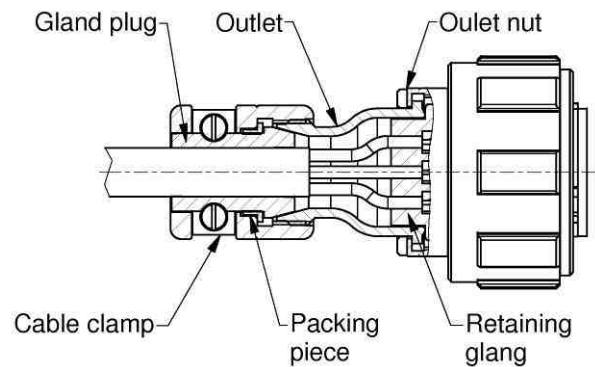

EARTH LINK FITTING DETAILS

EARTH LINK

Used in conjunction with outlet accessory sets to provide earth continuity to fixed and free bodies. To be fitted in accordance with instructions below and on packing label. Must be fitted to conform to the safety standards of CECC 75201-004

SHELL SIZE 1 AND SHELL SIZE 2

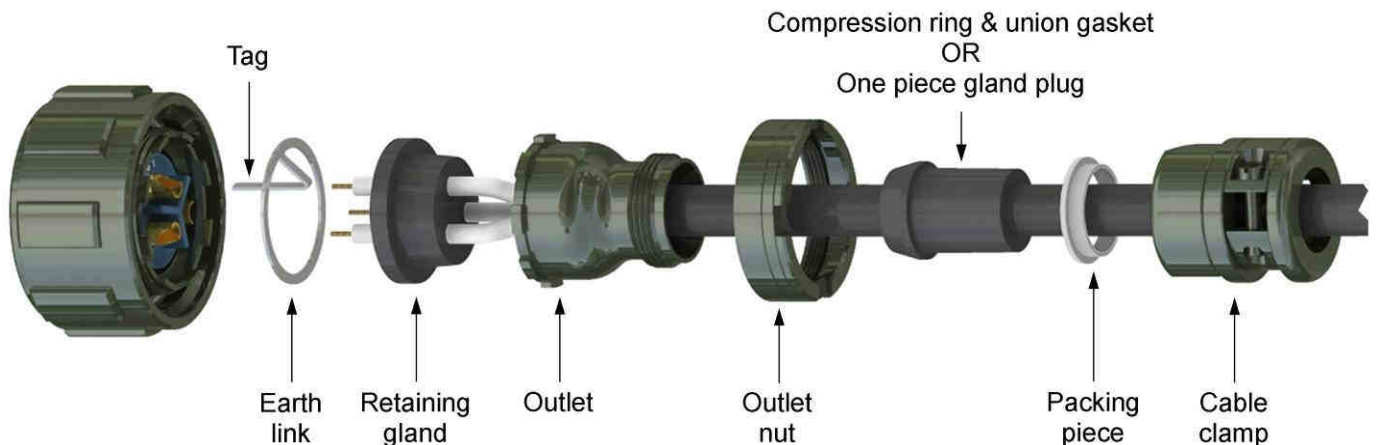

Earth link assembly details and fitting instructions

- Fit tag into solder bucket of earth terminal (E)
- Ensure rim of earth link is seated into shell recess.
- Solder brown lead into live terminal (L)
- Solder blue lead into neutral terminal (N)
- Solder green/yellow lead and earth link tag into earth terminal (E)
- Slide correctly orientated retaining gland firmly on to rim of earth link, assemble and tighten.

IMPORTANT

Maintain pressure on the outlet to ensure that the castellations on the outlet and the connector are located before tightening the outlet nut.

LMV RANGE PRODUCT SAFETY INFORMATION

These notes are intended to be used in conjunction with the Product Catalogue and Product Specification. Products may be safely used in the applications for which they have been designed and within the specified rating and environments. If products are exposed to conditions outside the performance ratings or specified environments they may constitute a hazard. In particular it should be noted that:-

1. Material Content

Circular Connectors generally use metalwork parts made of brass, aluminium, phosphor-bronze or steel, which, dependant on the particular application, may be passivated and protected with cadmium or zinc plate – in conjunction with chromated or anodised surface finishes. The insulating materials can either be natural or synthetic rubber, together with plastic or glass-filled plastic moulded parts. Contact materials vary but are usually made of brass, phosphor-bronze, alumel or chromel.

2. Electric Shock, Burns and Fire

Hazard can occur if the product is used outside the specified parameters or if the product is damaged, wrongly wired or poorly assembled, or poorly integrated into larger equipments, or contaminated with conductive fluids. Live circuit terminations must be protected and live circuits never broken by disconnecting products.

Hot spots may be created when resistance is increased due to damage or incorrect integration particularly soldering, or loose terminations. Overheating can cause breakdown of insulation, electric shock, burns or, ultimately, fire. In the event of fire noxious and/or toxic fumes may be released and, in these circumstances, any fire involving the product should be dealt with by personnel properly equipped. Connectors with exposed terminations or contacts should not be used on the current supply side of a circuit with exposed contacts on an unmated product. Before making a circuit live, the product and wiring should be checked to ensure there is no electrically conducting debris present. Circuit resistance checks should also be conducted before making the circuit live. Always ensure that connectors are assembled and wired by properly trained personnel.

3. Use, Transport and Storage of Products

Care must be exercised to avoid damage to any part of the products during transporting, storage or use. Abnormal transit or storage conditions and abuse during installation can give rise to damage. Products should not be used in a damaged condition.

Improper storage (particularly of damaged products) can give rise to additional hazards particularly corrosion. Attention is specifically drawn to the need for proper storage of products containing cadmium and you are advised to see the Guidance Note from the Health and safety Executive on Cadmium – Health and Safety Precautions.

4. Disposal of Products

Product should not be burnt.

SAFETY RULES

1. FOLLOW THE GUIDELINES GIVEN.
2. ALWAYS PROTECT LIVE CIRCUITS AND NEVER DISCONNECT A LIVE CONNECTOR.
3. NEVER USE A DAMAGED CONNECTOR.
4. NEVER BURN DISCARDED CONNECTORS.